

PARTICULARS
 LIGHTSHIP DISPLACEMENT: 1200 Kgs (S.W)
 LENGTH OVERALL 7.010 m
 LENGTH LOAD WATERLINE: 5.902 m
 BEAM AT DECK: 2.400 m
 BEAM AT DWL: 2.4000 m
 MAX FREEBOARD 0.600 m
 DEAD RISE AT TRANSOM 0°
 DRAFT: 0.092 m
 LCF 4.059 m AFT OF F.P
 PRISMATIC COEFFICIENT (Cp): 0.903
 BLOCK COEFFICIENT (Cb): 0.900
 WATERPLANE COEFFICIENT (Cw): 0.997
 KG/CM 145
 VCG: 0.348 m ABOVE KEEL
 LCG: 3.922 m AFT OF F.P
 LCB: 4.308 m AFT OF F.P
 VCB: 0.043m BELOW DWL
 BOUYANCY FOAM DENSITY: 30KG/M CUBIC
 BOUYANCY FOAM REQUIRED: NIL CUBIC M

ISOMETRIC VIEW

DESIGNER BOATS AUST

26 GREVILLE AVE SANCTUARY POINT 2540 N.S.W.
 TEL 02 44438540. FAX 02 44438470.
 WEB www.designerboats.com.au

TITLE **7M-WORK PUNT HULL**
ISOMETRIC VEIW

CLIENT

DRAWN BY P.H. BOOTH DATE 29/04/08

SCALE 1:20 DRG No D7-WP1-01 REV. 0 A3

DO NOT SCALE DRAWING

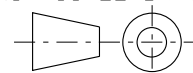

ALL DIMENSIONS IN MILLIMETRES

THIS DRAWING & DESIGN IS PROPERTY OF PETER BOOTH AND NOT TO BE COPIED IN WHOLE OR PART WITHOUT WRITTEN PERMISSION FROM PETER BOOTH

REVISION

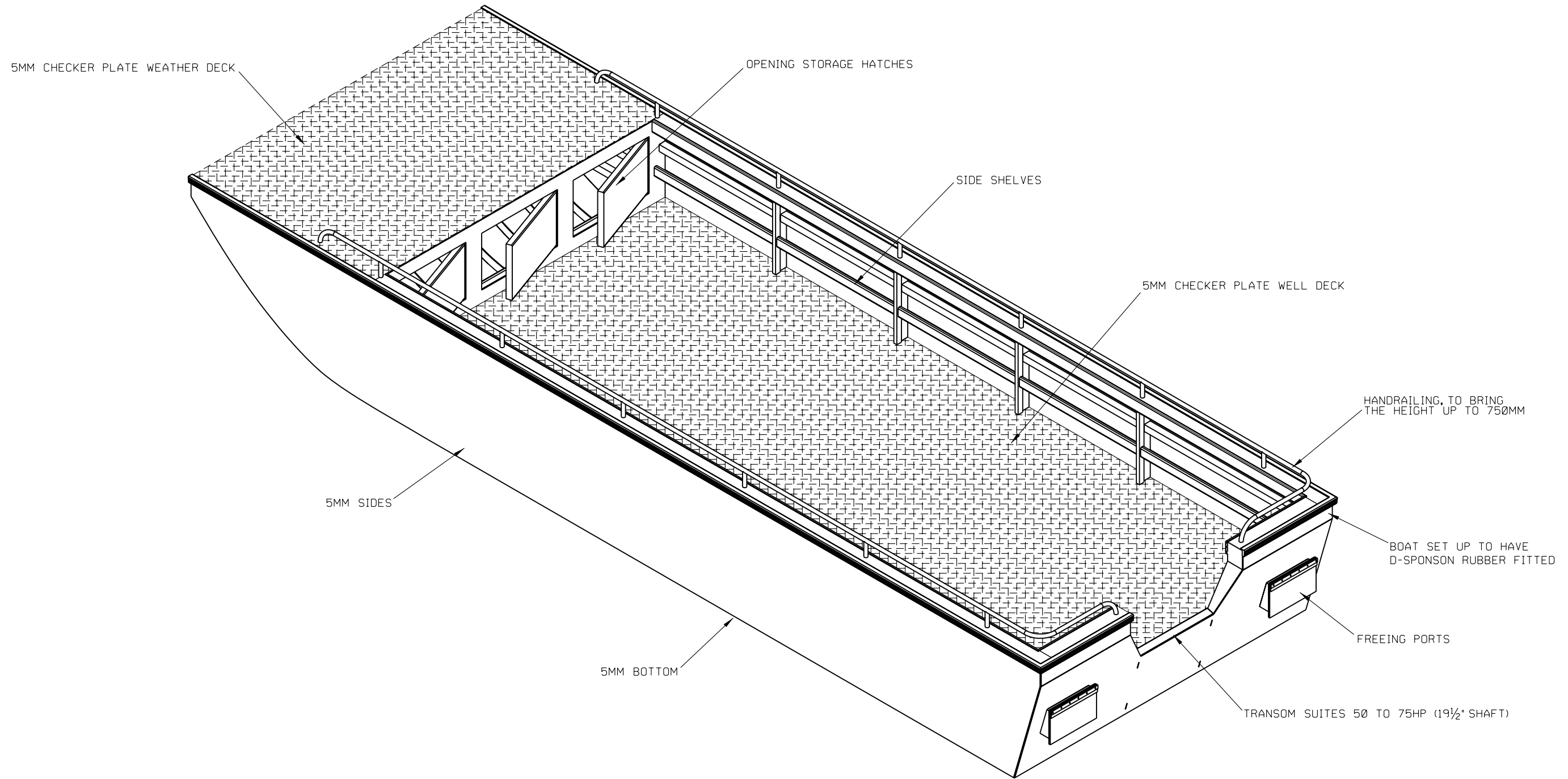

RIGHT ISOMETRIC VIEW

DESIGNER BOATS AUST

26 GREVILLE AVE SANCTUARY POINT 2540 N.S.W.
 TEL 02 44438540. FAX 02 44438470.
 WEB www.designerboats.com.au

TITLE 7M-WORK PUNT HULL
 RIGHT ISOMETRIC VEIW

CLIENT

DRAWN BY P.H. BOOTH DATE 29/04/08

SCALE 1:20 DRG No D7-WP1-02 REV. 0 A3

DO NOT SCALE DRAWING

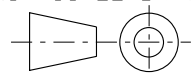

ALL DIMENSIONS IN MILLIMETRES

THIS DRAWING & DESIGN IS PROPERTY OF PETER BOOTH AND NOT TO BE COPIED IN WHOLE OR PART WITHOUT WRITTEN PERMISSION FROM PETER BOOTH

REVISION

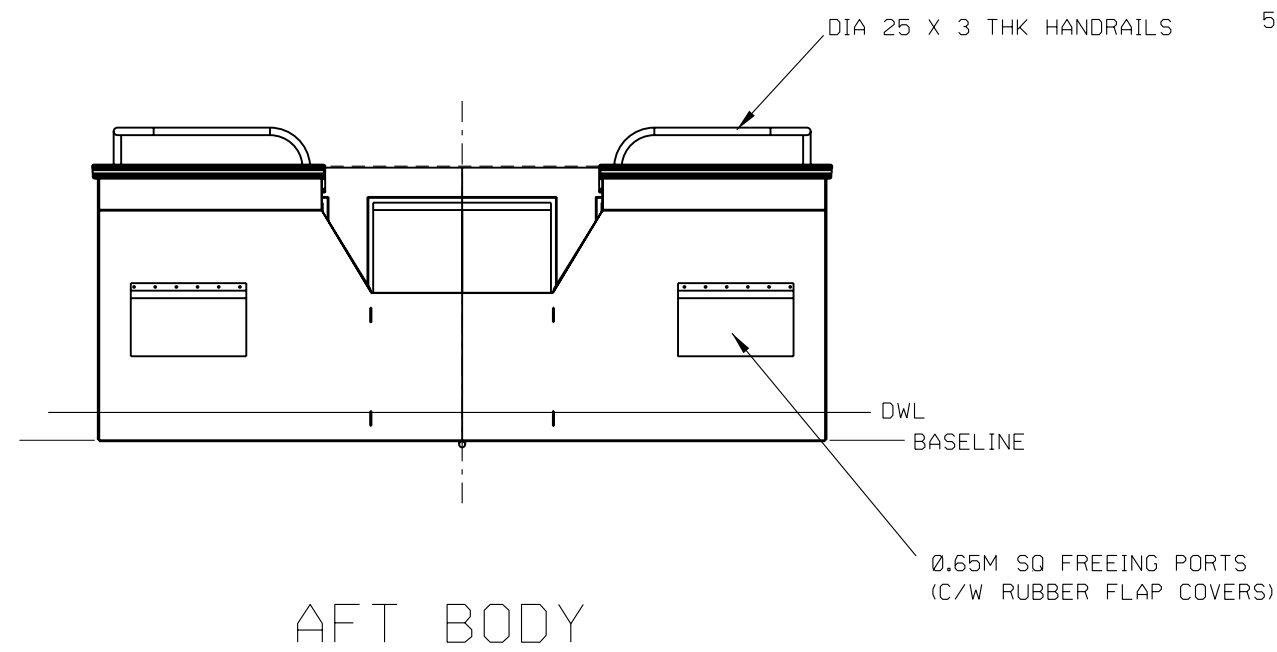

AFT BODY

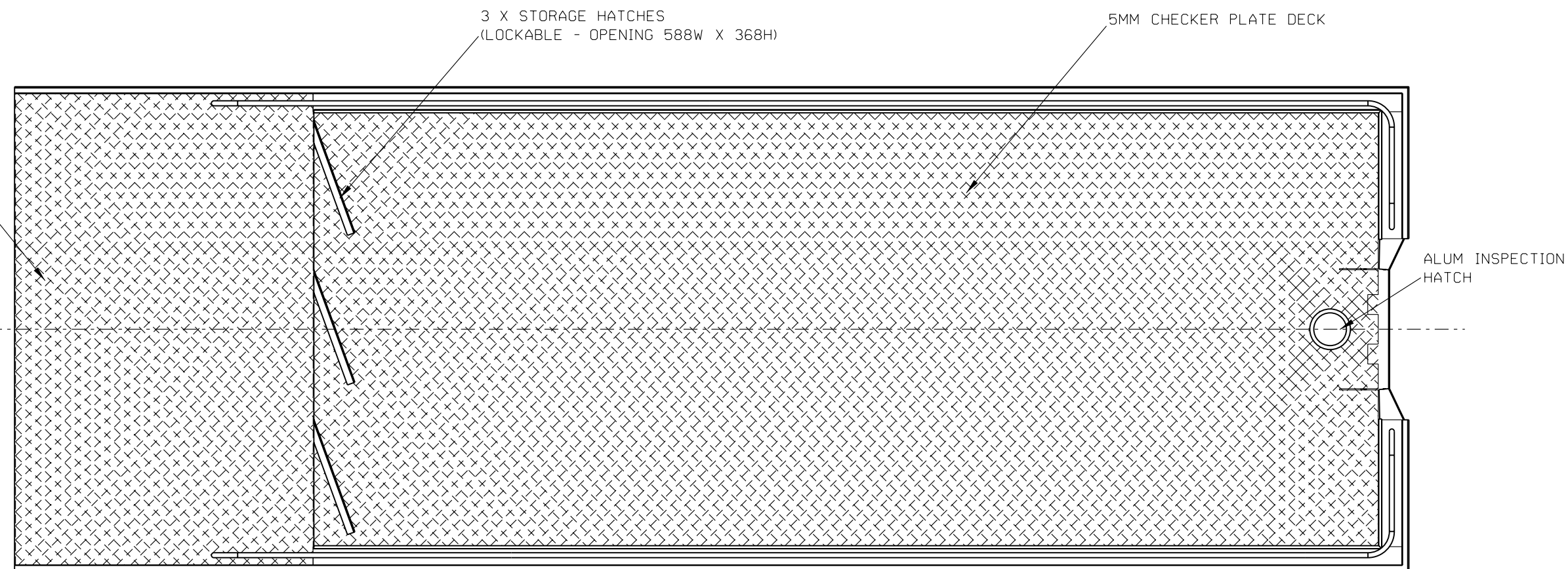

PLAN

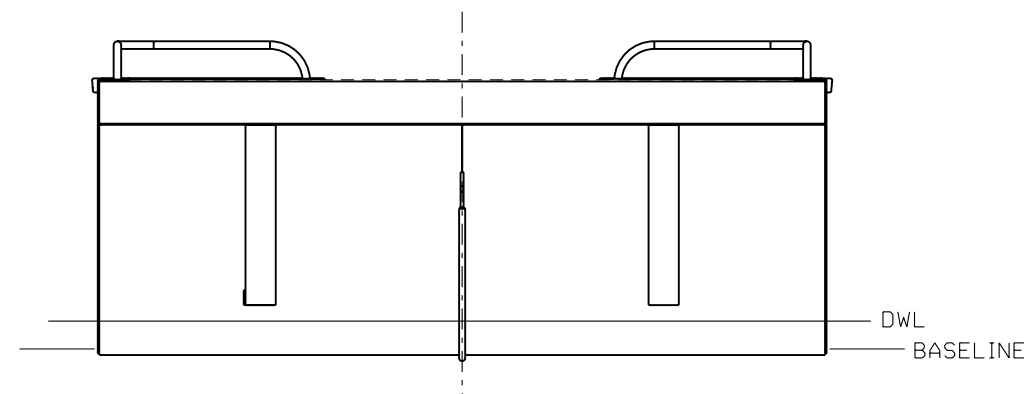

FWD BODY



PROFILE

PARTICULARS
LIGHTSHIP DISPLACEMENT: 1200 Kgs (S.W)
WORST CONDITION DISPLACEMENT: 4000 kgs
LENGTH OVERALL: 7.010 m
LENGTH LOAD WATERLINE: 5.902 m
BEAM AT DECK: 2.400 m
BEAM AT DWL: 2.4000 m
MAX FREEBOARD 0.600 m
DEAD RISE AT TRANSOM 0°
DRAFT: 0.092 m
ENGINE: 70 HP, TILLER (RECOM)
FUEL: 2 X 25 LITRE (PORTABLE TANKS)

DESIGNER BOATS AUST

26 GREVILLE AVE SANCTUARY POINT 2540 N.S.W.
TEL 02 44438540. FAX 02 44438470.
WEB. www.designerboats.com.au

TITLE **7M-WORK PUNT HULL**
GENERAL ARRANGEMENT

CLIENT

DRAWN BY P.H. BOOTH DATE 29/04/08

SCALE 1:25 DRG No D7-WP1-03 REV. 0 A2

DO NOT SCALE DRAWING
ALL DIMENSIONS IN MILLIMETRES

THIS DRAWING & DESIGN IS PROPERTY OF PETER BOOTH AND NOT TO BE COPIED IN WHOLE OR PART WITHOUT WRITTEN PERMISSION FROM PETER BOOTH

REVISION

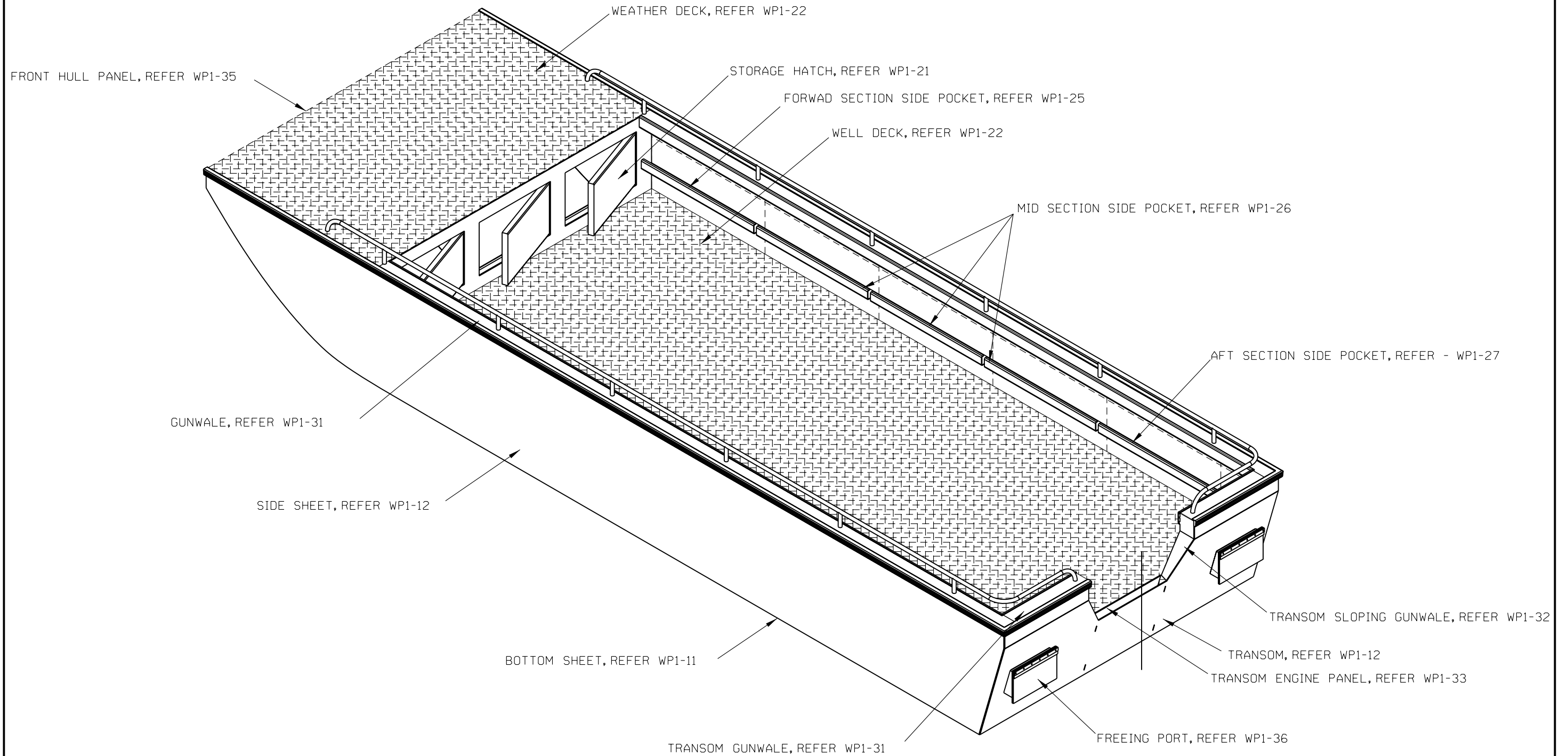

PLATE ARRANGEMENT

DESIGNER BOATS AUST

26 GREVILLE AVE SANCTUARY POINT 2540 N.S.W.
 TEL 02 44438540. FAX 02 44438470.
 WEB www.designerboats.com.au

TITLE **7M-WORK PUNT HULL
 PLATE ARRANGEMENT**

CLIENT

DO NOT SCALE DRAWING

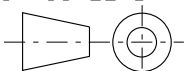

ALL DIMENSIONS IN
 MILLIMETRES

THIS DRAWING & DESIGN
 IS PROPERTY OF
 PETER BOOTH AND NOT TO BE
 COPIED IN WHOLE OR PART
 WITHOUT WRITTEN PERMISSION
 FROM PETER BOOTH

DRAWN BY P.H. BOOTH

DATE 29/04/08

SCALE 1:25

DRG No D7-WP1-04

REV. 0

A3

REVISION

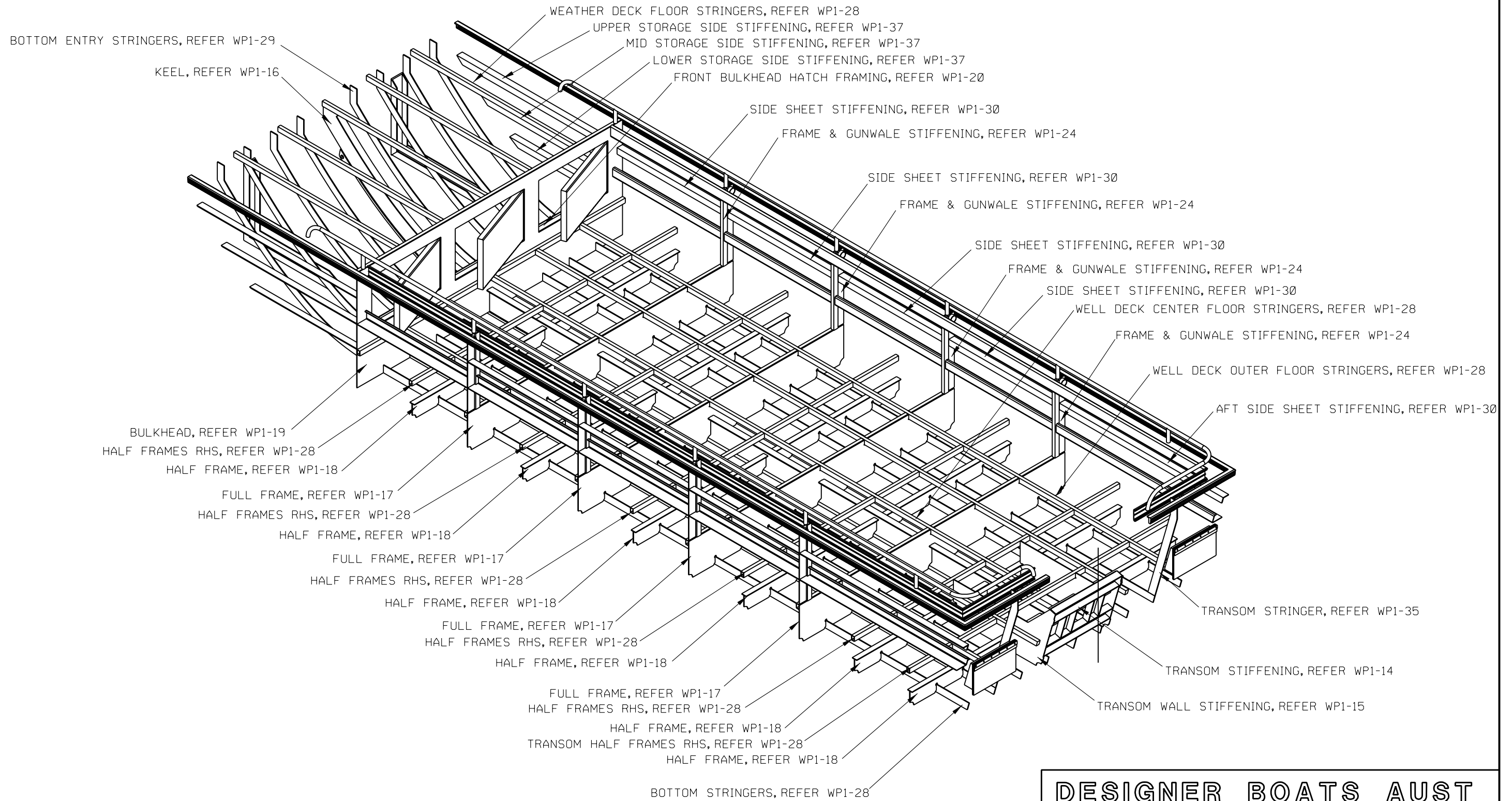

STRUCTURAL ARRANGEMENT

DESIGNER BOATS AUST

26 GREVILLE AVE SANCTUARY POINT 2540 N.S.W.
 TEL 02 44438540. FAX 02 44438470.
 WEB www.designerboats.com.au

TITLE 7M-WORK PUNT HULL
 STRUCTURAL ARRANGEMENT

CLIENT

DO NOT SCALE DRAWING

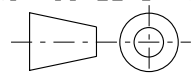

ALL DIMENSIONS IN
 MILLIMETRES

THIS DRAWING & DESIGN
 IS PROPERTY OF
 PETER BOOTH AND NOT TO BE
 COPIED IN WHOLE OR PART
 WITHOUT WRITTEN PERMISSION
 FROM PETER BOOTH

DRAWN BY P.H. BOOTH

DATE 29/04/08

SCALE 1:25

DRG No D7-WP1-05

REV. 0

A3

REVISION