

PARTICULARS

DISPLACEMENT: 2010 Kgs (S.W)
 LENGTH OVERALL 7.602 m
 LENGTH LOAD WATERLINE: 6.422 m
 BEAM AT DECK: 2.340 m
 BEAM AT DWL: 2.184 m
 MAX FREEBOARD 1.175 m
 DEAD RISE AT TRANSOM 16°
 DRAFT: 0.365 m
 LCF 4.865 m AFT OF F.P
 PRISMATIC COEFFICIENT (Cp): 0.735
 BLOCK COEFFICIENT (Cb): 0.384
 WATERPLANE COEFFICIENT (Cw): 0.778
 KG/CM 112
 VCG: .737 m ABOVE KEEL
 LCG: 5.124 m AFT OF F.P
 LCB: 4.954 m AFT OF F.P
 VCB: 0.119m BELOW DWL
 BOUYANCY FOAM DENSITY: 30KG/M CUBIC
 BOUYANCY FOAM REQUIRED: 1.6 M CUBIC

DESIGNER BOATS AUST
 26 GREVILLE AVE SANCTUARY POINT 2540 N.S.W.
 TEL 02 44438540. FAX 02 44438470.
 WEB www.designerboats.com.au

TITLE **7.6M-T1 HULL & POD**
ISOMETRIC VIEW

CLIENT

ISOMETRIC VIEW

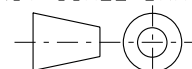
DO NOT SCALE DRAWING

 ALL DIMENSIONS IN
 MILLIMETRES

THIS DRAWING & DESIGN
 IS PROPERTY OF
 PETER BOOTH AND NOT TO BE
 COPIED IN WHOLE OR PART
 WITHOUT WRITTEN PERMISSION
 FROM PETER BOOTH

DRAWN BY P.H. BOOTH

DATE 3/09/09

SCALE
 1:25

DRG No
 D76-T1-01

REV.
 0

A3

REVISION

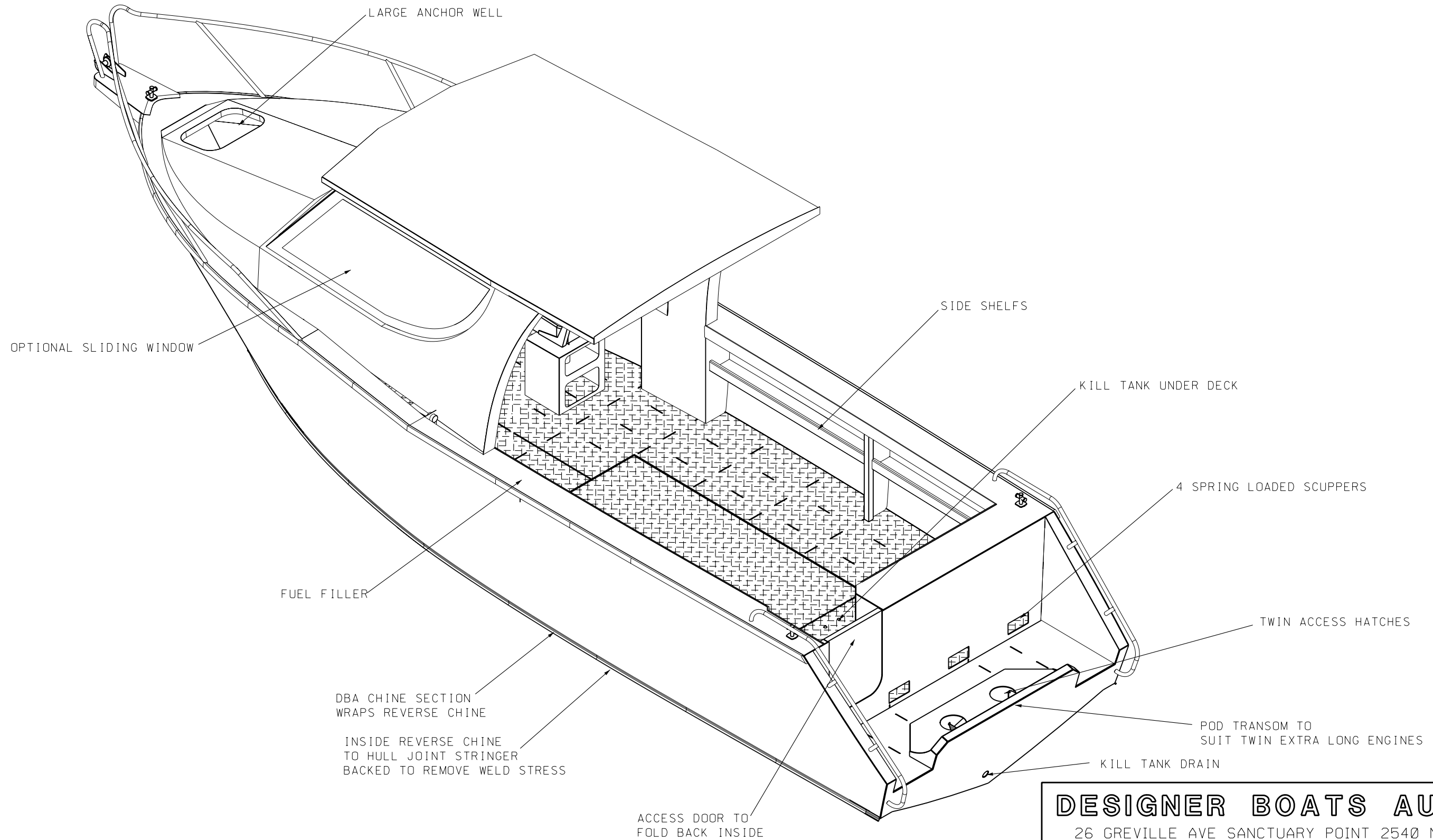

RIGHT ISOMETRIC VIEW

DESIGNER BOATS AUST

26 GREVILLE AVE SANCTUARY POINT 2540 N.S.W.
 TEL 02 44438540. FAX 02 44438470.
 WEB www.designerboats.com.au

TITLE 7.6M-T1 HULL & POD
 RIGHT ISOMETRIC VIEW

CLIENT

DRAWN BY P.H. BOOTH

DATE 3/09/09

SCALE 1:25

DRG No D76-T1-02

REV. 0

A3

DO NOT SCALE DRAWING

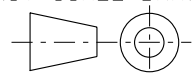

ALL DIMENSIONS IN MILLIMETRES

THIS DRAWING & DESIGN IS PROPERTY OF PETER BOOTH AND NOT TO BE COPIED IN WHOLE OR PART WITHOUT WRITTEN PERMISSION FROM PETER BOOTH

REVISION

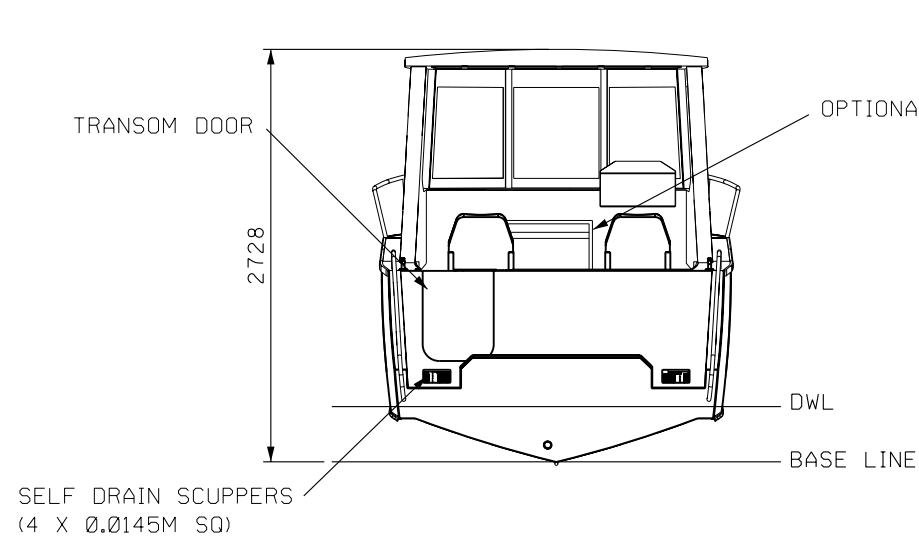

REAR BODY

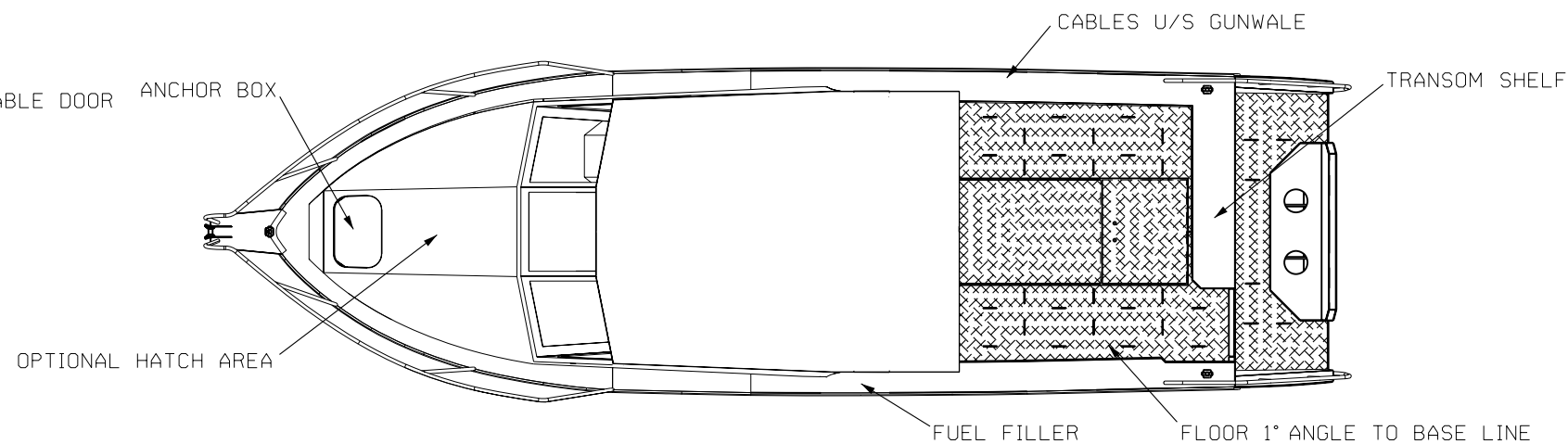

PLAN

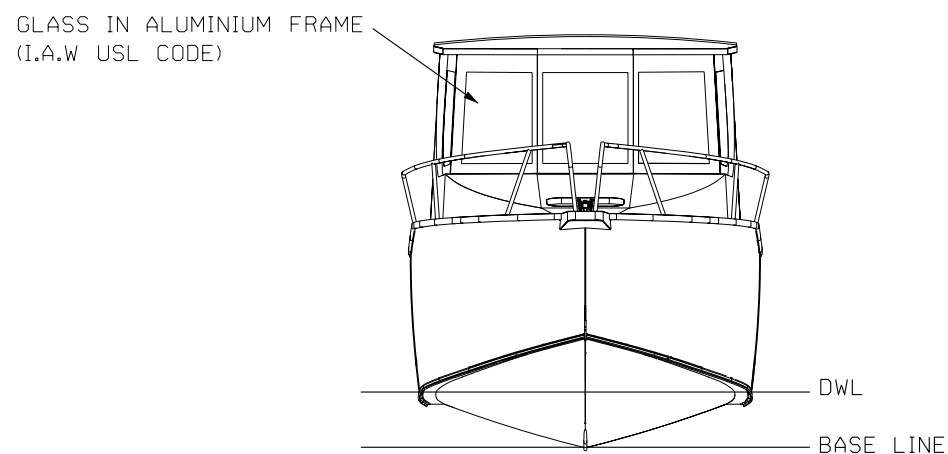

BODY

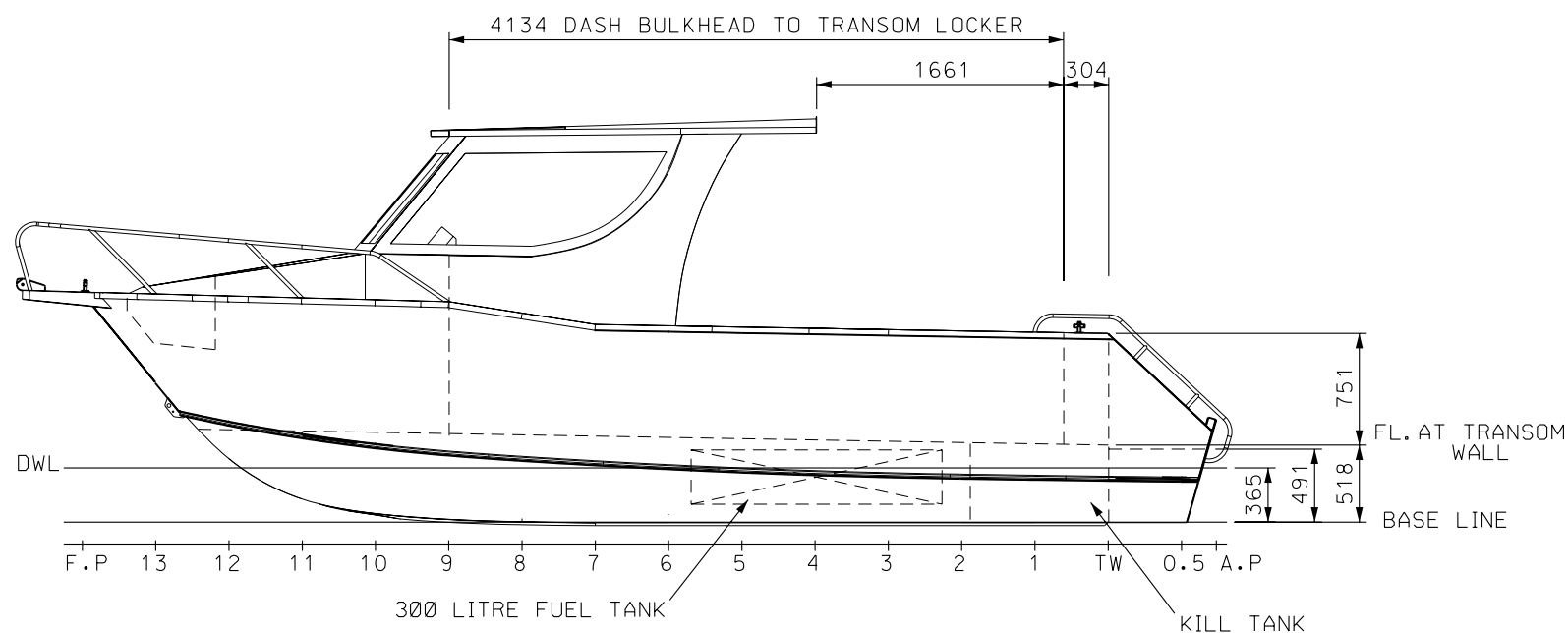

PROFILE

PARTICULARS

DISPLACEMENT @ READY TO GO (NO PASS): 2010 Kgs (S.W)
 LENGTH OVERALL 7.602 m
 LENGTH LOAD WATERLINE: 6.422 m
 BEAM AT DECK: 2.340 m
 BEAM AT DWL: 2.184 m
 MAX FREEBOARD 1.175 m
 DEAD RISE AT TRANSOM 16°
 DRAFT: 0.365 m
 MAX: 260 HP
 MASS CONTROLS, MOTOR & BATTERIES: 340 x 2 = 640KGS
 FUEL: 300 LITRES

DESIGNER BOATS AUST

26 GREVILLE AVE SANCTUARY POINT 2540 N.S.W.
 TEL 02 44438540. FAX 02 44438470.
 WEB www.designerboats.com.au

TITLE 7.6M-T1 HULL & POD
 GENERAL ARRANGEMENT

CLIENT

DO NOT SCALE DRAWING

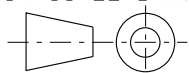

ALL DIMENSIONS IN
MILLIMETRES

THIS DRAWING & DESIGN
IS PROPERTY OF
PETER BOOTH AND NOT TO BE
COPIED IN WHOLE OR PART
WITHOUT WRITTEN PERMISSION
FROM PETER BOOTH

DRAWN BY P.H. BOOTH

DATE 3/09/09

SCALE
1:50

DRG No
D76-T1-03

REV.
0

A3

REVISION

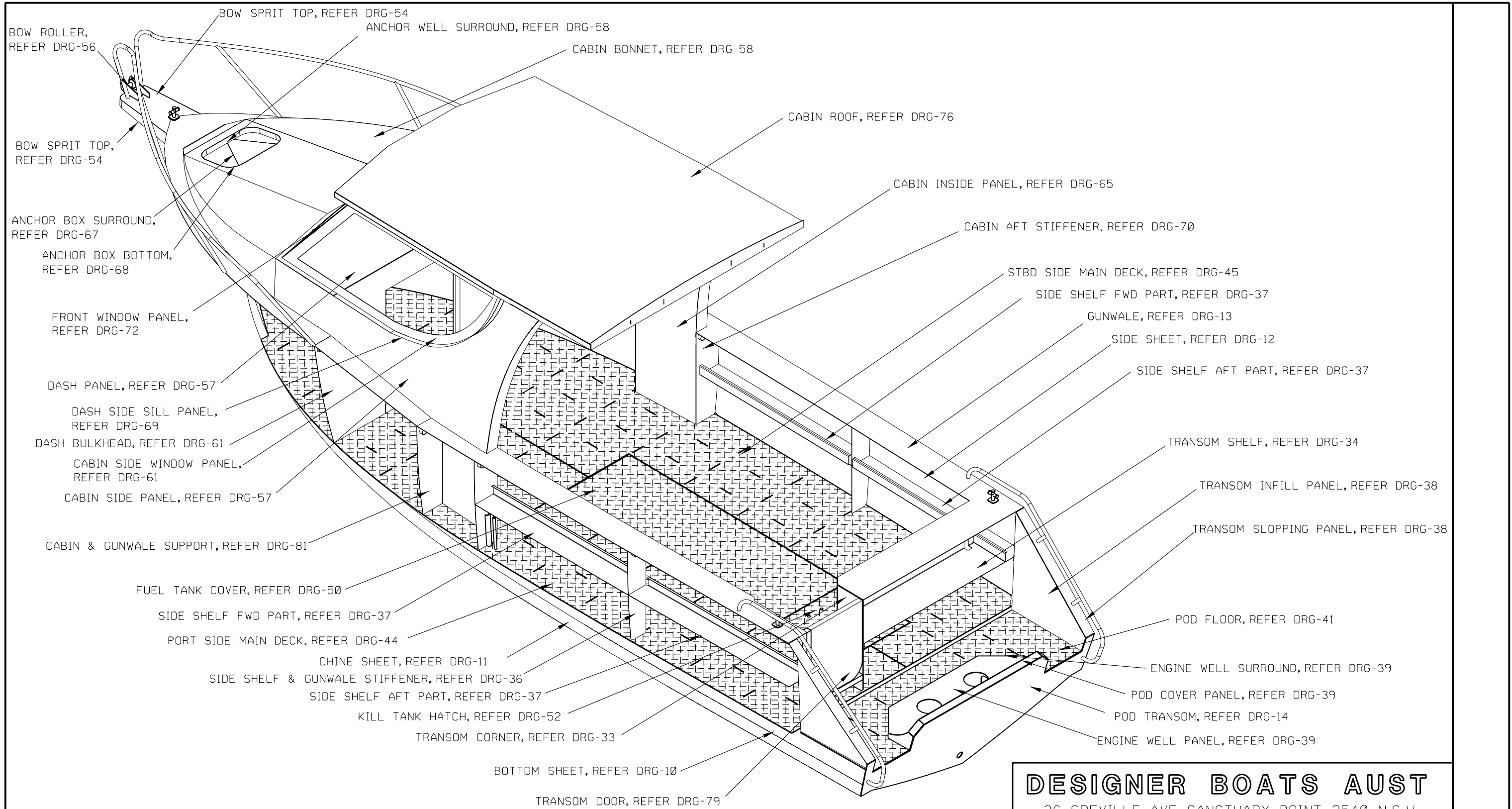
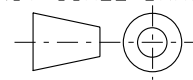

PLATE ARRANGEMENT

DESIGNER BOATS AUST
 26 GREVILLE AVE SANCTUARY POINT 2540 N.S.W.
 TEL 02 44438540. FAX 02 44438470.
 WEB www.designerboats.com.au

TITLE **7.6M-T1 HULL & POD
 PLATE ARRANGEMENT**

CLIENT

DO NOT SCALE DRAWING

 ALL DIMENSIONS IN
 MILLIMETRES

THIS DRAWING & DESIGN
 IS PROPERTY OF
 PETER BOOTH AND NOT TO BE
 COPIED IN WHOLE OR PART
 WITHOUT WRITTEN PERMISSION
 FROM PETER BOOTH

DRAWN BY P.H. BOOTH

DATE 3/09/09

SCALE
 1:25

DRG No
 D76-T1-04

REV.
 0

A3

REVISION

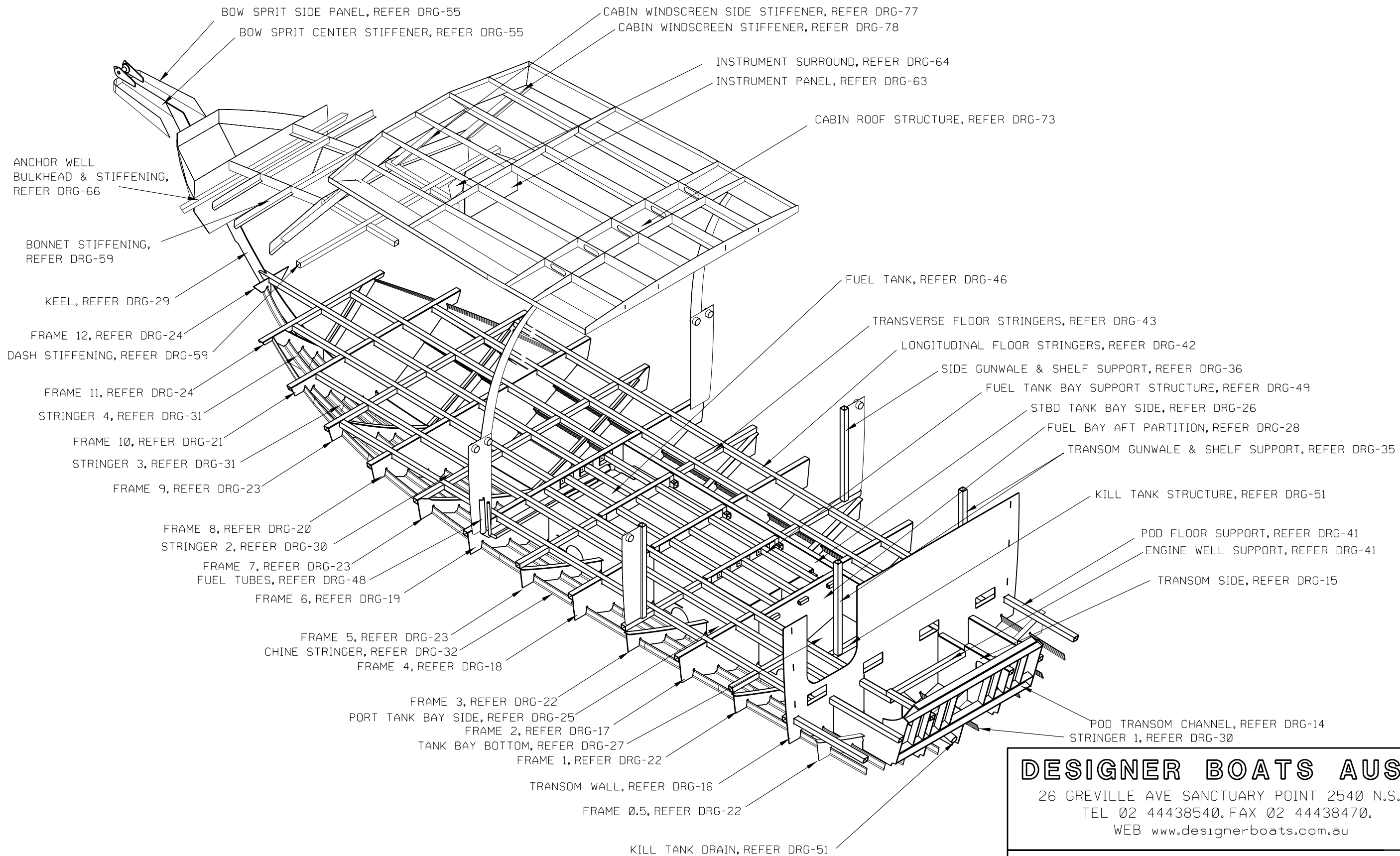

STRUCTURE ARRANGEMENT

DESIGNER BOATS AUST

26 GREVILLE AVE SANCTUARY POINT 2540 N.S.W.
 TEL 02 44438540. FAX 02 44438470.
 WEB www.designerboats.com.au

TITLE 7.6M-T1 HULL & POD
 STRUCTURE ARRANGEMENT

CLIENT

DRAWN BY P.H. BOOTH

DATE 3/09/09

SCALE 1:25

DRG No D76-T1-05

REV. 0

A3

DO NOT SCALE DRAWING

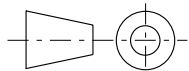

ALL DIMENSIONS IN MILLIMETRES

THIS DRAWING & DESIGN IS PROPERTY OF PETER BOOTH AND NOT TO BE COPIED IN WHOLE OR PART WITHOUT WRITTEN PERMISSION FROM PETER BOOTH

REVISION

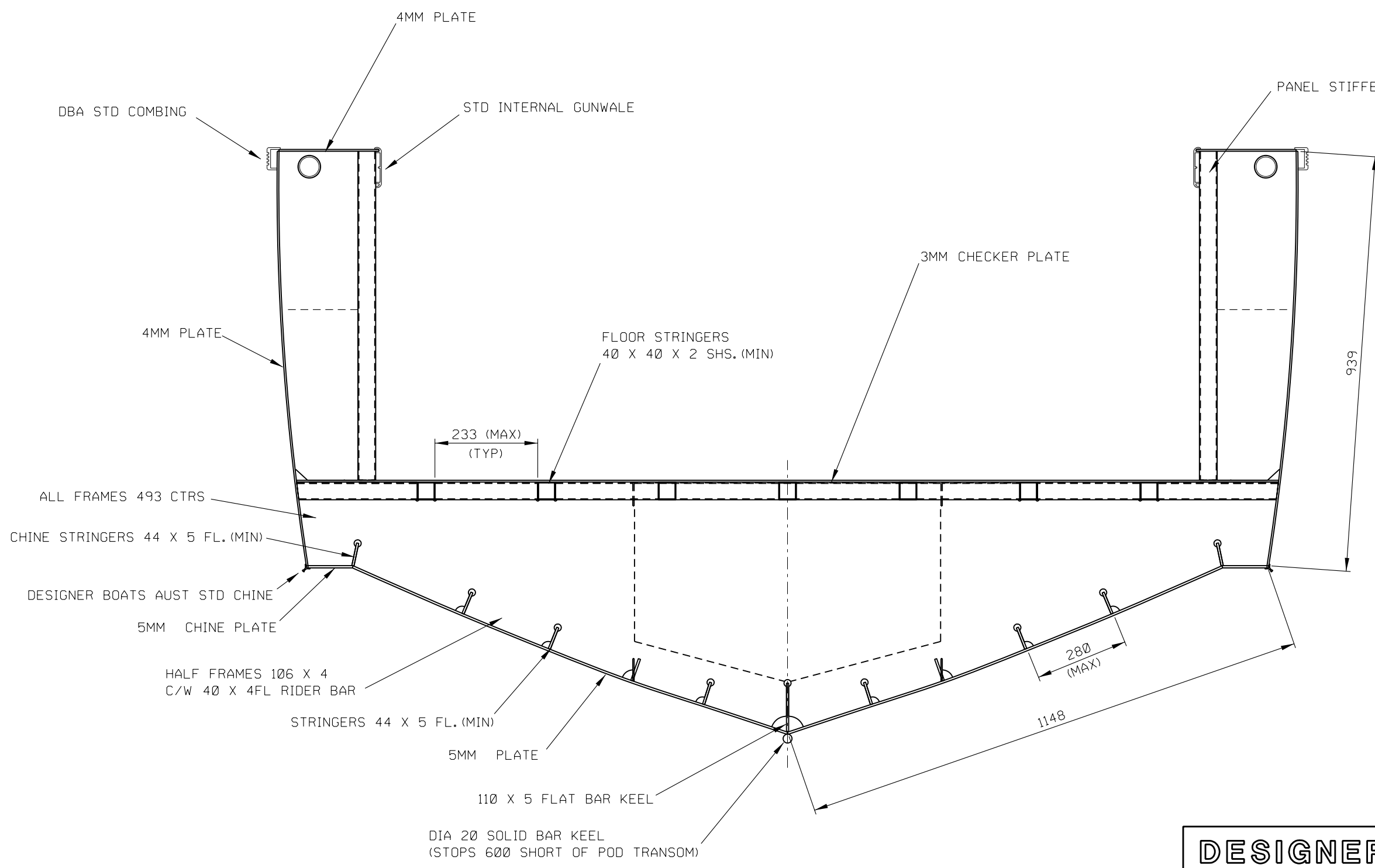

MIDSHIP SECTION

DESIGNER BOATS AUST
 26 GREVILLE AVE SANCTUARY POINT 2540 N.S.W.
 TEL 02 44438540. FAX 02 44438470.
 WEB www.designerboats.com.au

TITLE **7.6M-T1 HULL & POD**
MIDSHIP SECTION

CLIENT

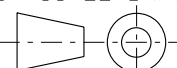
DO NOT SCALE DRAWING

 ALL DIMENSIONS IN
 MILLIMETRES

THIS DRAWING & DESIGN
 IS PROPERTY OF
 PETER BOOTH AND NOT TO BE
 COPIED IN WHOLE OR PART
 WITHOUT WRITTEN PERMISSION
 FROM PETER BOOTH

DRAWN BY P.H. BOOTH

DATE 3/09/09

SCALE
 1:25

DRG No
 D76-T1-07

REV.
 0

A3

REVISION

7.6M MAHI-MAHI

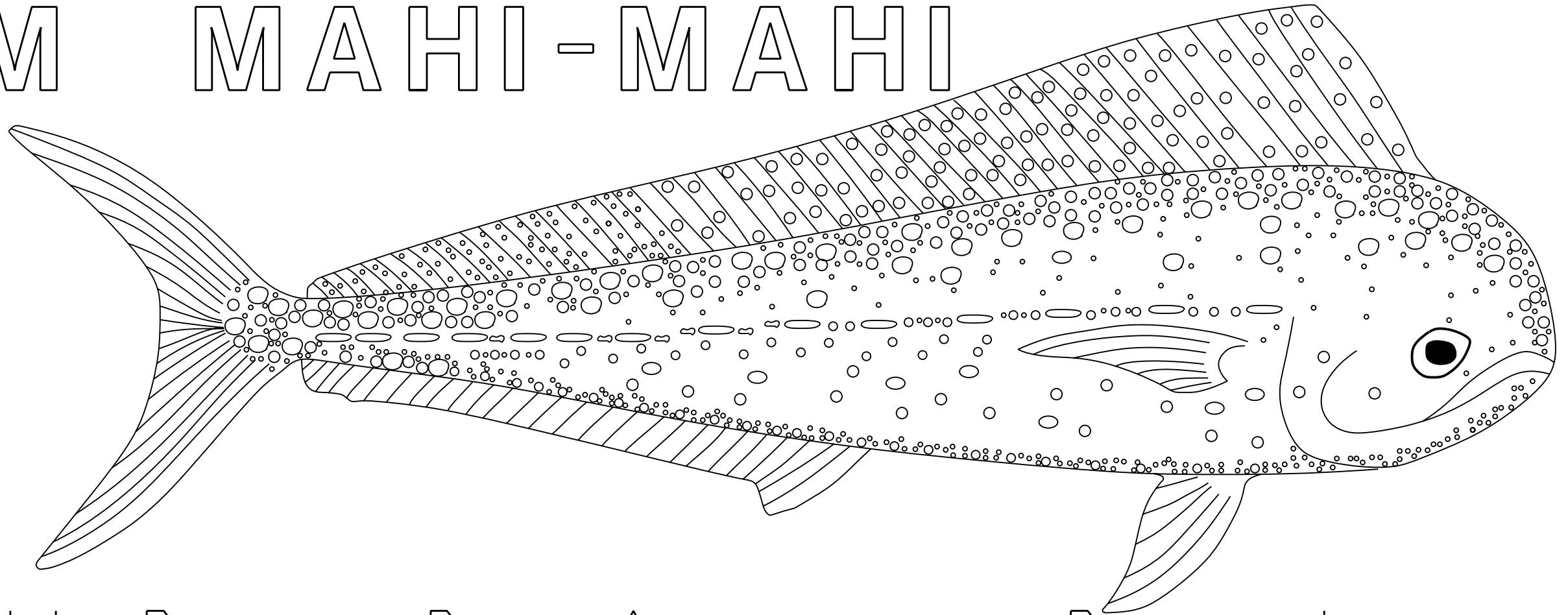

Designed by Designer Boats Aust

www.Designerboats.com.au

7.6M MAHI-MAHI

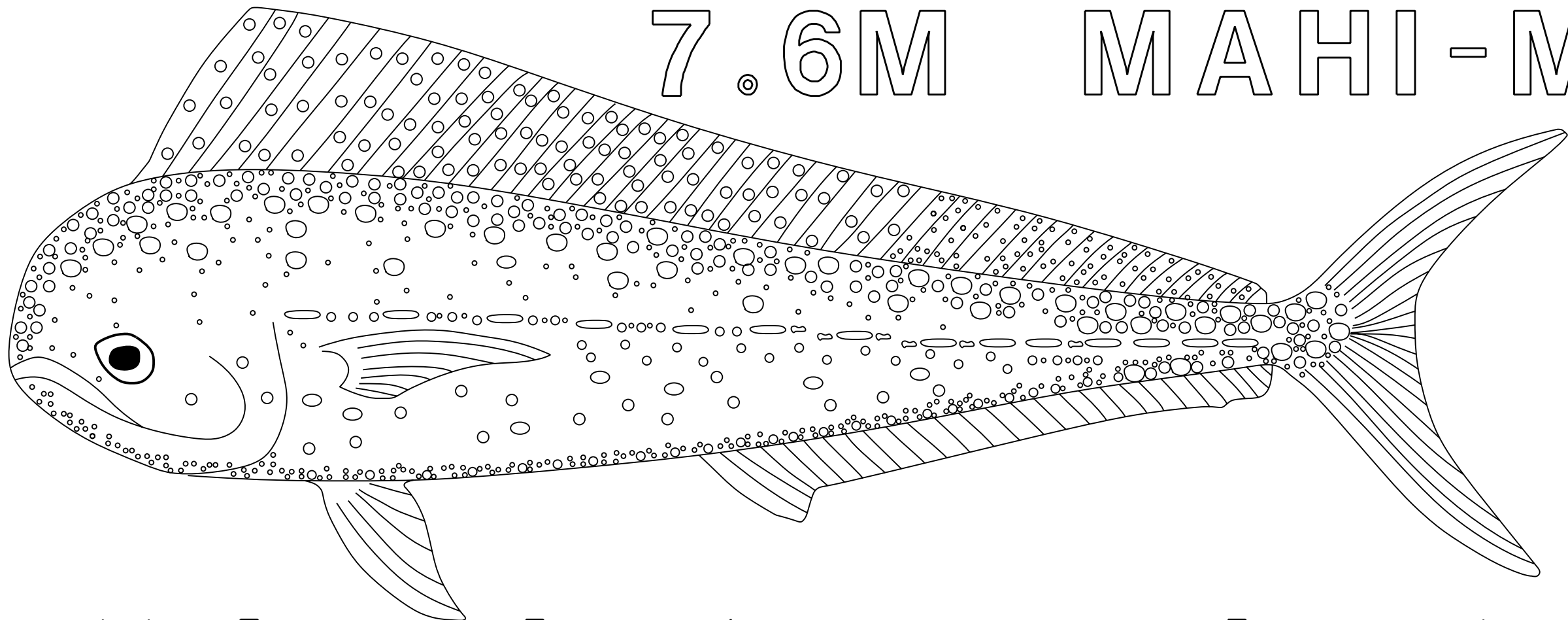

Designed by Designer Boats Aust

www.Designerboats.com.au