

PARTICULARS

DISPLACEMENT: 1134 Kgs (S.W)
 LENGTH OVERALL 6.510 m
 LENGTH LOAD WATERLINE: 5.315 m
 BEAM AT DECK: 2.386 m
 BEAM AT DWL: 1.828 m
 MAX FREEBOARD 1.047 m
 DEAD RISE AT TRANSOM 11.5°
 DRAFT: 0.268 m
 LCF 4.191 m AFT OF F.P
 PRISMATIC COEFFICIENT (Cp): 0.732
 BLOCK COEFFICIENT (Cb): 0.425
 WATERPLANE COEFFICIENT (Cw): 0.775
 KG/CM 77.361
 VCG: 0.600 m ABOVE KEEL
 LCG: 4.509 m AFT OF F.P
 LCB: 4.283 m AFT OF F.P
 VCB: 0.093 m BELOW DWL

ISOMETRIC VIEW

DESIGNER BOATS AUST

26 GREVILLE AVE SANCTUARY POINT 2540 N.S.W.
 TEL 02 44438540. FAX 02 44438470.
 WEB: www.designerboats.com.au

TITLE **6.5M T4 HULL & POD**
ISOMETRIC VIEW

CLIENT

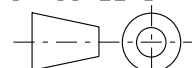
DO NOT SCALE DRAWING

 ALL DIMENSIONS IN
 MILLIMETRES

THIS DRAWING IS PROPERTY OF
 PETER BOOTH AND NOT TO BE
 COPIED IN WHOLE OR PART
 WITHOUT WRITTEN PERMISSION
 FROM PETER BOOTH

DRAWN BY P.H. BOOTH		DATE 23/01/09	
SCALE 1:20	DRG No D65-T4-01	REV. 0	A3

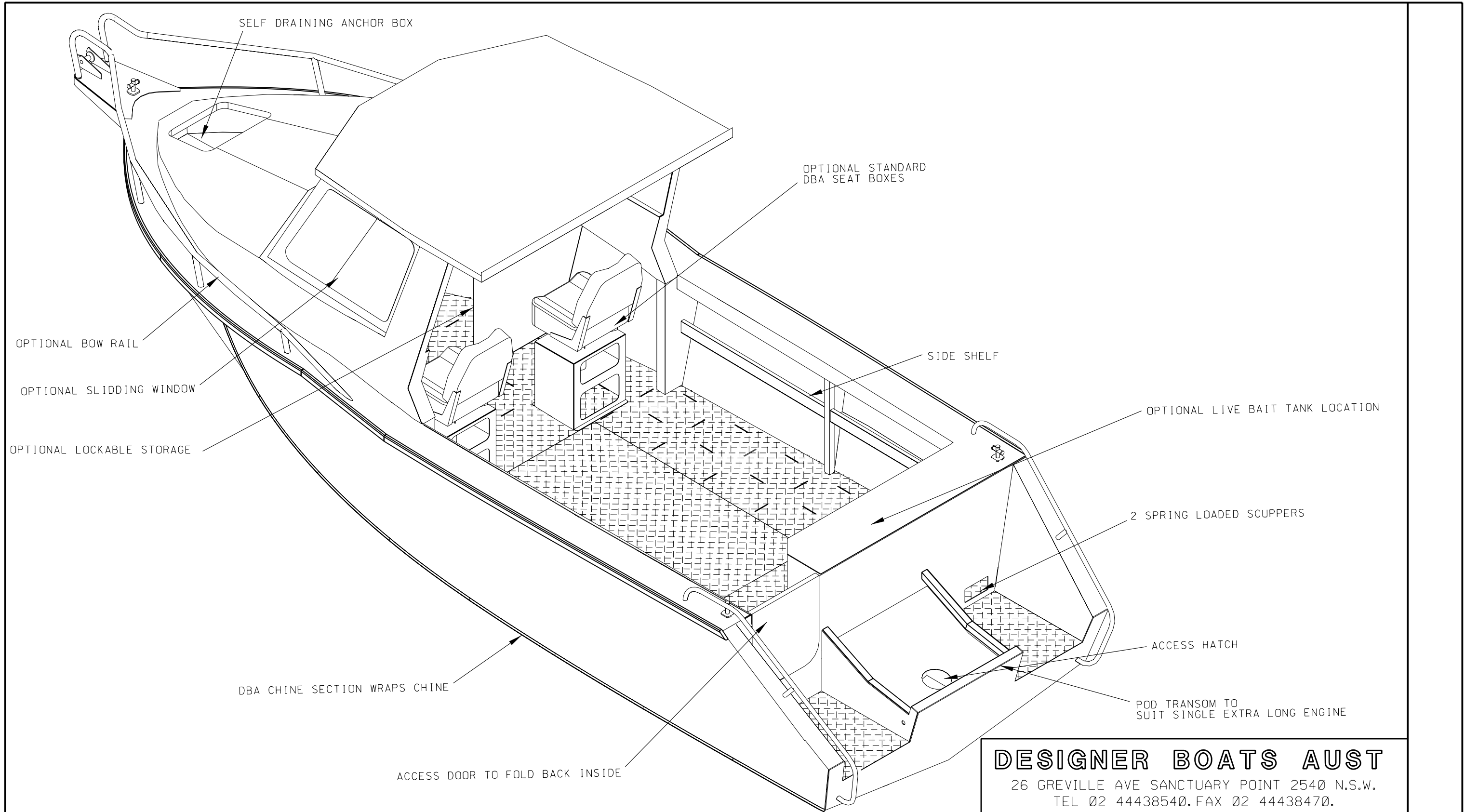
REVISION



RIGHT ISOMETRIC VIEW

DESIGNER BOATS AUST

26 GREVILLE AVE SANCTUARY POINT 2540 N.S.W.
 TEL 02 44438540. FAX 02 44438470.
 WEB: www.designerboats.com.au

TITLE **6.5M T4 HULL & POD
 RIGHT ISOMETRIC VIEW**

CLIENT

DRAWN BY P.H. BOOTH

DATE 23/01/09

SCALE 1:20

DRG No D65-T4-02

REV. 0

A3

DO NOT SCALE DRAWING

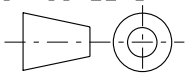

ALL DIMENSIONS IN MILLIMETRES

THIS DRAWING IS PROPERTY OF PETER BOOTH AND NOT TO BE COPIED IN WHOLE OR PART WITHOUT WRITTEN PERMISSION FROM PETER BOOTH

REVISION

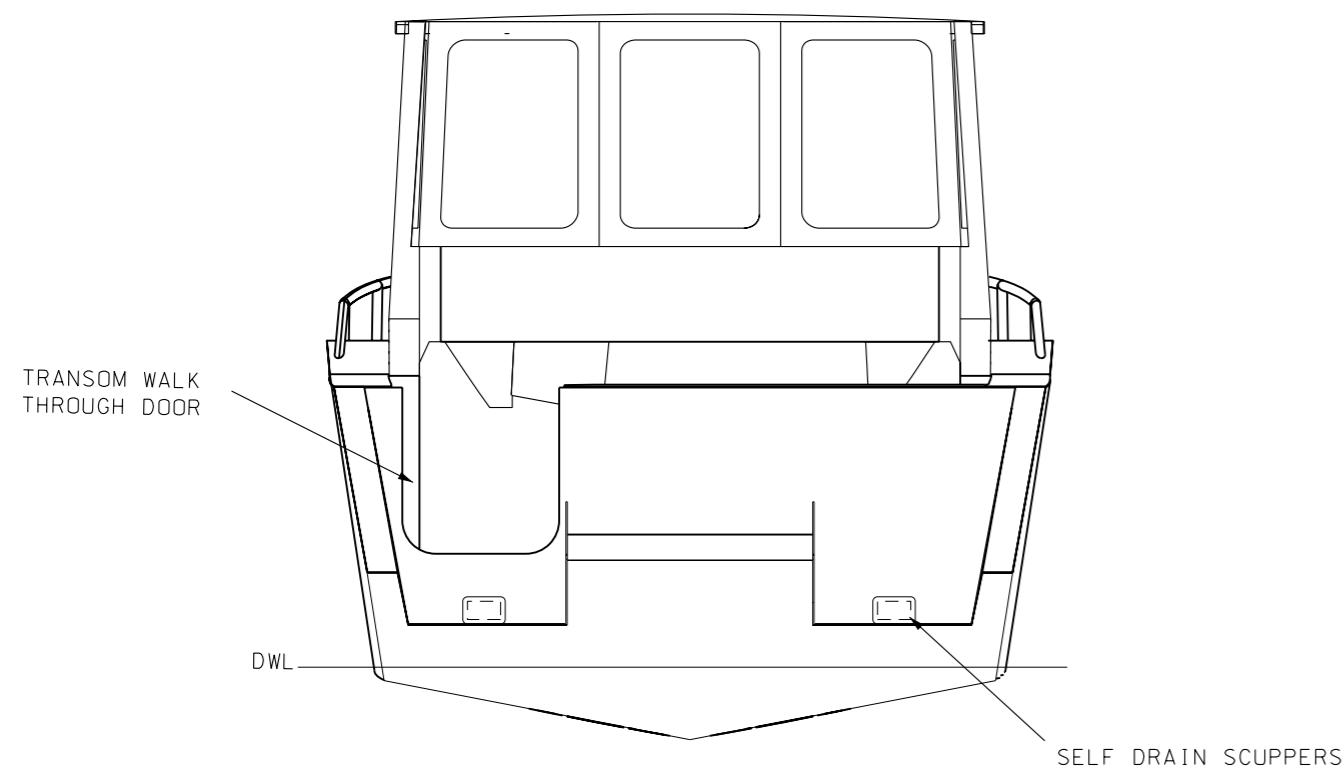

REAR BODY

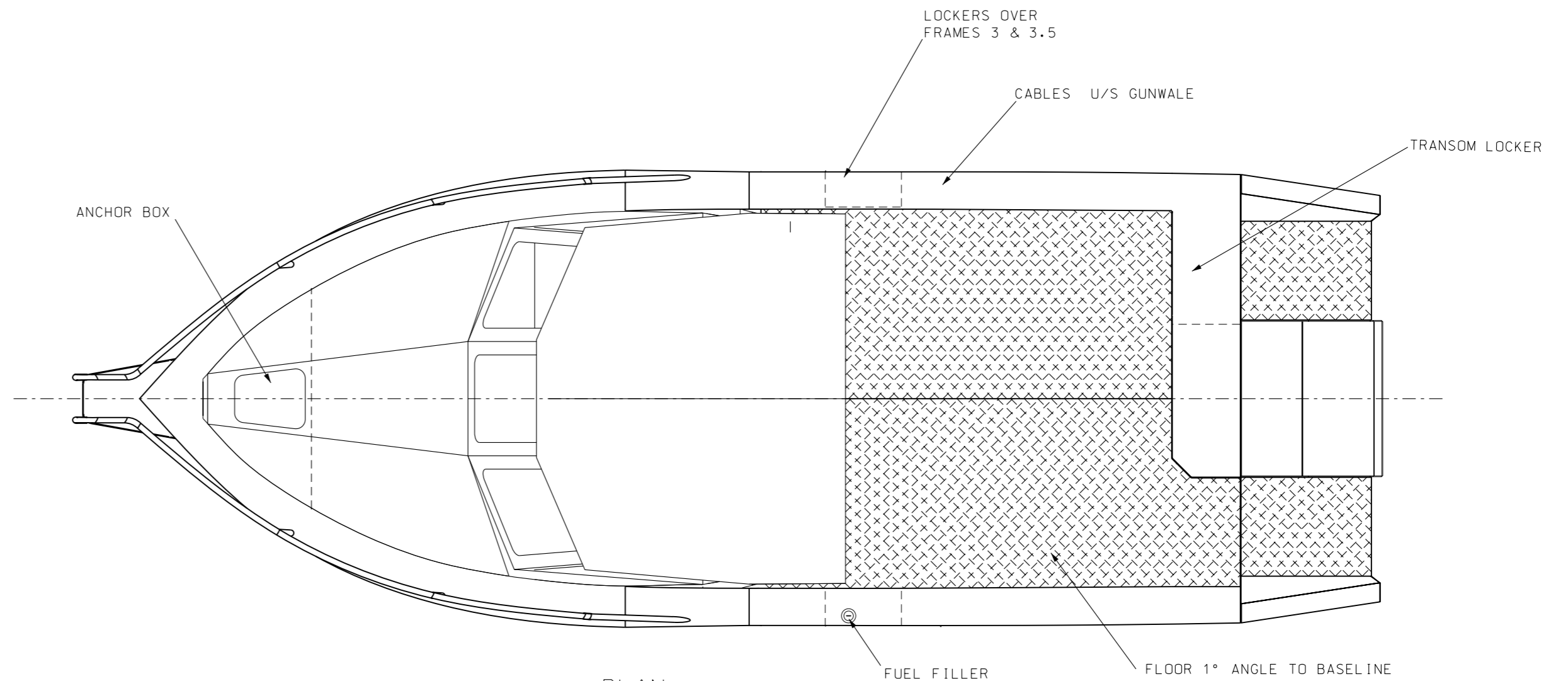
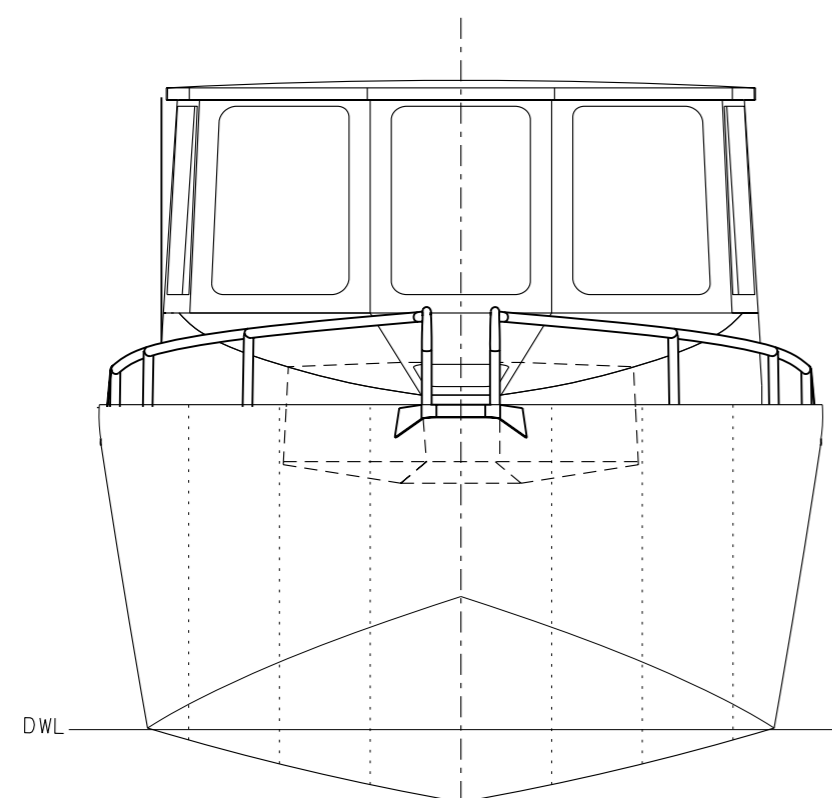

PLAN

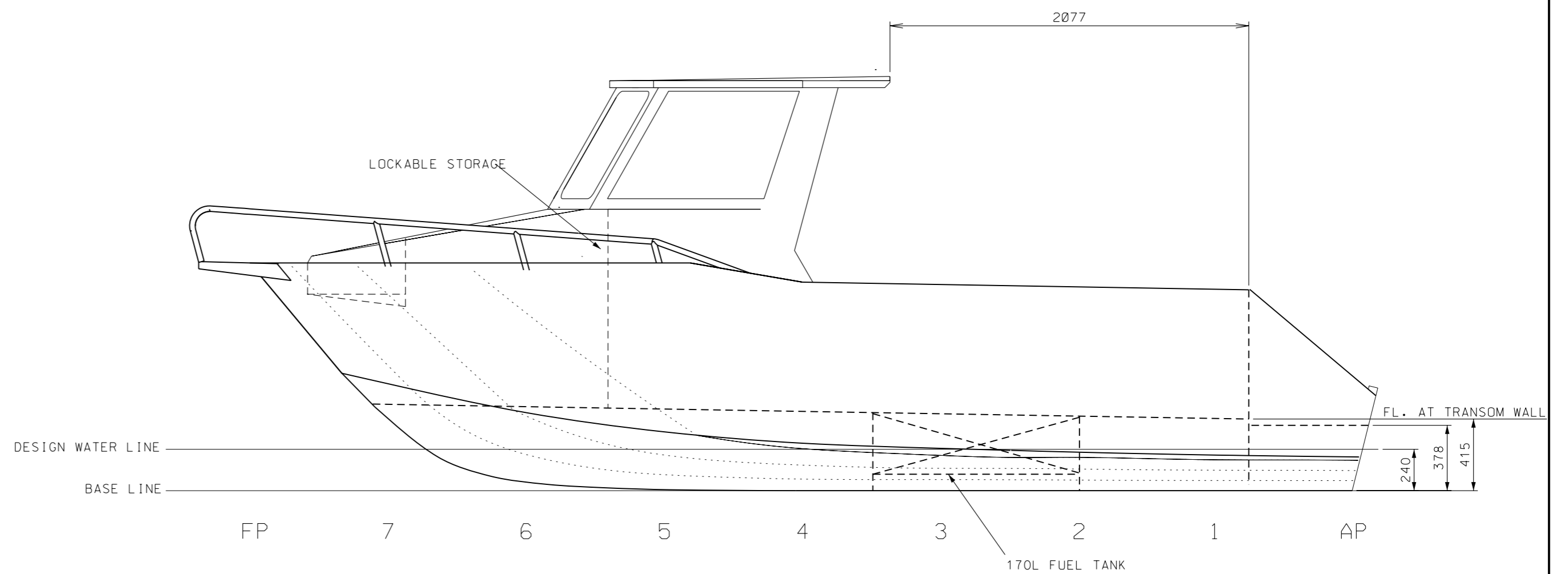

PROFILE

PARTICULARS

DISPLACEMENT: 1131 Kgs (S.W)
 LENGTH OVERALL: 6.510 m
 LENGTH LOAD WATERLINE: 5.315 m
 BEAM AT DECK: 2.386 m
 BEAM AT DWL: 1.838 m
 MAX FREEBOARD: 1.047 m
 DEAD RISE AT TRANSOM: 11.5°
 DRAFT: .268 m
 ENGINE: 200 HP (MAX)
 FUEL: 170 LITRES

DESIGNER BOATS AUST

26 GREVILLE AVE SANCTUARY POINT 2540 N.S.W.
 TEL 02 44438540. FAX 02 44438470.
 WEB: www.designerboats.com.au

TITLE 6.5M T4 HULL & POD
 GENERAL ARRANGEMENT

CLIENT

DRAWN BY P.H. BOOTH DATE 23/01/09

SCALE 1:25 DRG No D65-T4-03 REV. 0 A2

DO NOT SCALE DRAWING

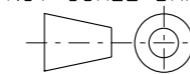

ALL DIMENSIONS IN MILLIMETRES

THIS DRAWING IS PROPERTY OF PETER BOOTH AND NOT TO BE COPIED IN WHOLE OR PART WITHOUT WRITTEN PERMISSION FROM PETER BOOTH

REVISION

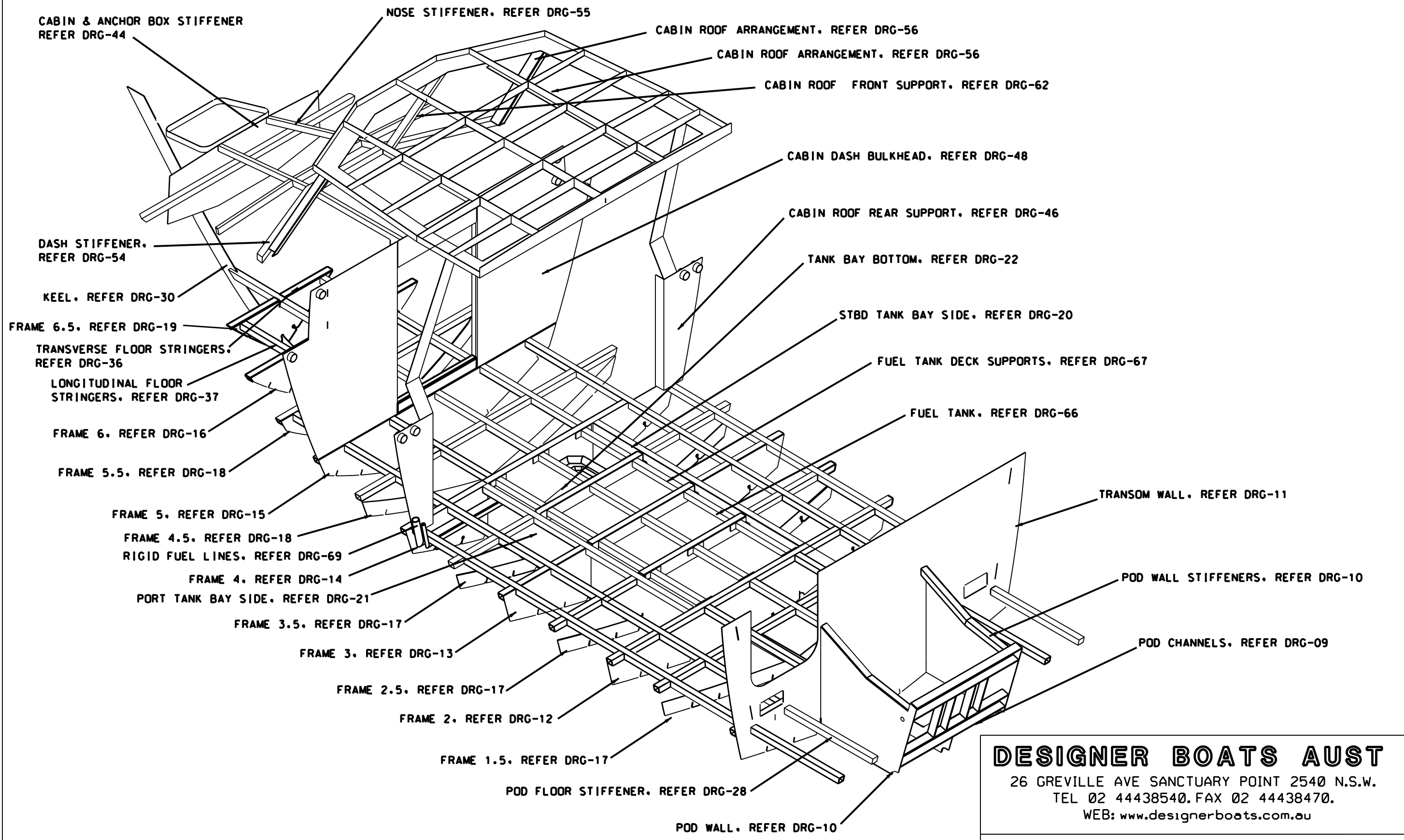

CABIN & ANCHOR BOX STIFFENER
REFER DRG-44

NOSE STIFFENER. REFER DRG-55

CABIN ROOF ARRANGEMENT. REFER DRG-56

CABIN ROOF ARRANGEMENT. REFER DRG-56

CABIN ROOF FRONT SUPPORT. REFER DRG-62

CABIN DASH BULKHEAD. REFER DRG-48

CABIN ROOF REAR SUPPORT. REFER DRG-46

DASH STIFFENER.
REFER DRG-54

TANK BAY BOTTOM. REFER DRG-22

KEEL. REFER DRG-30

STBD TANK BAY SIDE. REFER DRG-20

FRAME 6.5. REFER DRG-19

TRANSVERSE FLOOR STRINGERS.
REFER DRG-36

FUEL TANK DECK SUPPORTS. REFER DRG-67

LONGITUDINAL FLOOR
STRINGERS. REFER DRG-37

FUEL TANK. REFER DRG-66

FRAME 6. REFER DRG-16

FRAME 5.5. REFER DRG-18

TRANSOM WALL. REFER DRG-11

FRAME 5. REFER DRG-15

FRAME 4.5. REFER DRG-18

RIGID FUEL LINES. REFER DRG-69

FRAME 4. REFER DRG-14

PORT TANK BAY SIDE. REFER DRG-21

FRAME 3.5. REFER DRG-17

FRAME 3. REFER DRG-13

POD WALL STIFFENERS. REFER DRG-10

FRAME 2.5. REFER DRG-17

FRAME 2. REFER DRG-12

POD CHANNELS. REFER DRG-09

FRAME 1.5. REFER DRG-17

POD FLOOR STIFFENER. REFER DRG-28

POD WALL. REFER DRG-10

DESIGNER BOATS AUST

26 GREVILLE AVE SANCTUARY POINT 2540 N.S.W.
TEL 02 44438540. FAX 02 44438470.
WEB: www.designerboats.com.au

TITLE **6.5M T4 HULL & POD
STRUCTURE ARRANGEMENT**

CLIENT

DO NOT SCALE DRAWING

ALL DIMENSIONS IN
MILLIMETRES

THIS DRAWING IS PROPERTY OF
PETER BOOTH AND NOT TO BE
COPIED IN WHOLE OR PART
WITHOUT WRITTEN PERMISSION
FROM PETER BOOTH

DRAWN BY P.H. BOOTH

DATE 23/01/09

SCALE
1:20

DRG No
D65-T4-04

REV.
0

A3

REVISION

STRUCTURE ARRANGEMENT

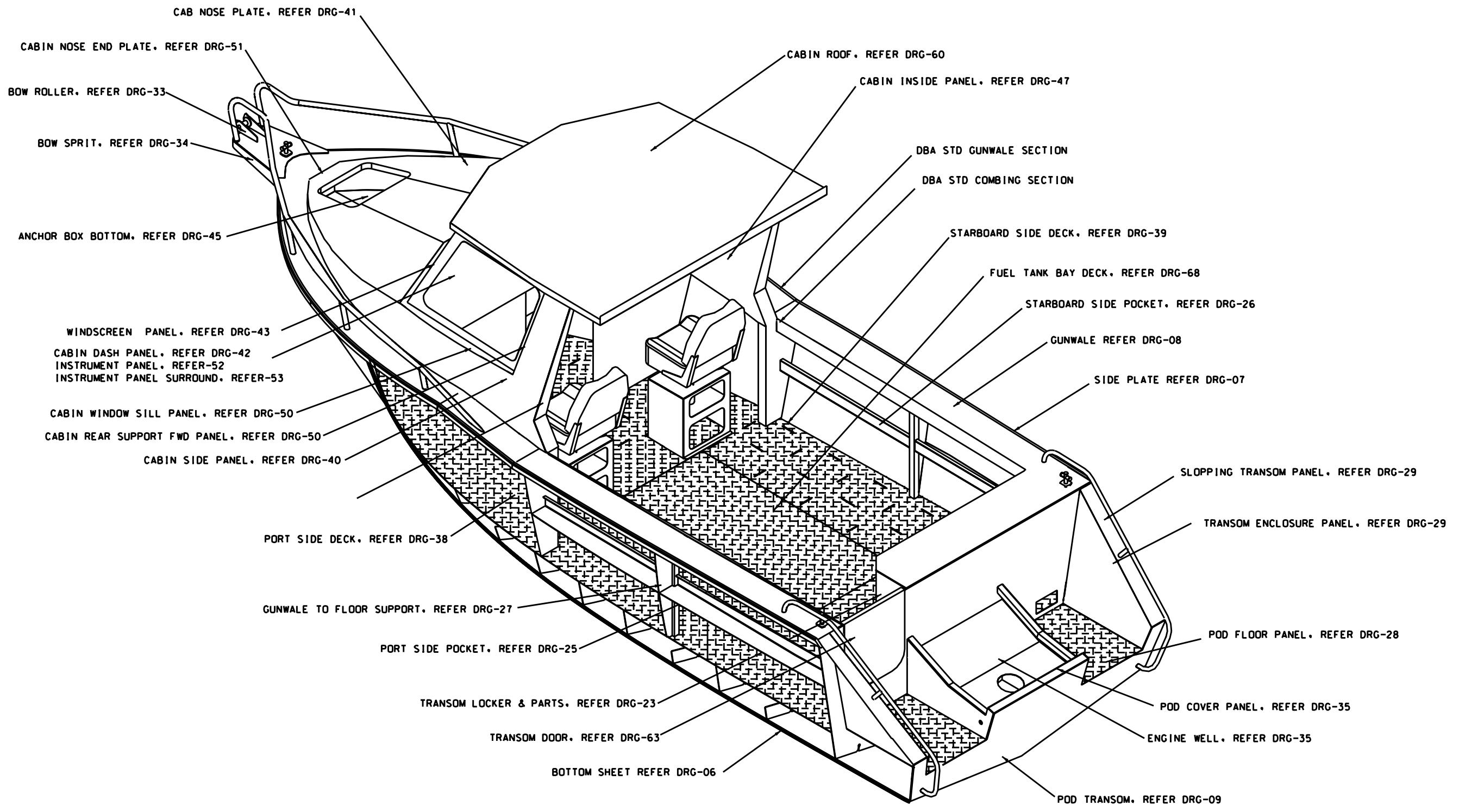

CAB NOSE PLATE. REFER DRG-41

CABIN NOSE END PLATE. REFER DRG-51

BOW ROLLER. REFER DRG-33

BOW SPRIT. REFER DRG-34

ANCHOR BOX BOTTOM. REFER DRG-45

WINDSCREEN PANEL. REFER DRG-43

CABIN DASH PANEL. REFER DRG-42

INSTRUMENT PANEL. REFER-52

INSTRUMENT PANEL SURROUND. REFER-53

CABIN WINDOW SILL PANEL. REFER DRG-50

CABIN REAR SUPPORT FWD PANEL. REFER DRG-50

CABIN SIDE PANEL. REFER DRG-40

PORT SIDE DECK. REFER DRG-38

GUNWALE TO FLOOR SUPPORT. REFER DRG-27

PORT SIDE POCKET. REFER DRG-25

TRANSOM LOCKER & PARTS. REFER DRG-23

TRANSOM DOOR. REFER DRG-63

BOTTOM SHEET REFER DRG-06

CABIN ROOF. REFER DRG-60

CABIN INSIDE PANEL. REFER DRG-47

DBA STD GUNWALE SECTION

DBA STD COMBING SECTION

STARBOARD SIDE DECK. REFER DRG-39

FUEL TANK BAY DECK. REFER DRG-68

STARBOARD SIDE POCKET. REFER DRG-26

GUNWALE REFER DRG-08

SIDE PLATE REFER DRG-07

SLOPPING TRANSOM PANEL. REFER DRG-29

TRANSOM ENCLOSURE PANEL. REFER DRG-29

POD FLOOR PANEL. REFER DRG-28

POD COVER PANEL. REFER DRG-35

ENGINE WELL. REFER DRG-35

POD TRANSOM. REFER DRG-09

PLATE ARRANGEMENT

DESIGNER BOATS AUST

26 GREVILLE AVE SANCTUARY POINT 2540 N.S.W.
 TEL 02 44438540. FAX 02 44438470.
 WEB: www.designerboats.com.au

TITLE 6.5M T4 HULL & POD
 PLATE ARRANGEMENT

CLIENT

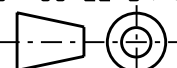
DO NOT SCALE DRAWING

 ALL DIMENSIONS IN
 MILLIMETRES

THIS DRAWING IS PROPERTY OF
 PETER BOOTH AND NOT TO BE
 COPIED IN WHOLE OR PART
 WITHOUT WRITTEN PERMISSION
 FROM PETER BOOTH

DRAWN BY P.H. BOOTH

DATE 23/01/09

SCALE 1:25

DRG No D65-T4-05

REV. 0

A3

REVISION