

PARTICULARS

DISPLACEMENT: 2040 Kgs (S.W)
 LENGTH OVERALL 8.816 m
 LENGTH LOAD WATERLINE: 7.241 m
 BEAM AT DECK: 2.450 m
 BEAM AT DWL: 2.194 m
 MAX FREEBOARD 1.327 m
 DEAD RISE AT TRANSOM 14"
 DRAFT: 0.288 m
 LCF 5.683 m AFT OF F.P
 PRISMATIC COEFFICIENT (Cp): 0.763
 BLOCK COEFFICIENT(Cb): 0.435
 WATERPLANE COEFFICIENT (Cw): 0.824
 KG/CM 134.5
 VCG: 0.426 m ABOVE KEEL
 LCG: 6049 m AFT OF F.P
 LCB: 5.822 m AFT OF F.P
 VCB: 0.095m BELOW DWL
 BOUYANCY FOAM DENSITY: 30KG/M CUBIC
 BOUYANCY FOAM REQUIRED: 2.0 M CUBIC

ISOMETRIC VIEW

DESIGNER BOATS AUST

26 GREVILLE AVE SANCTUARY POINT 2540 N.S.W.
 TEL 02 44438540. FAX 02 44438470.
 WEB: www.designerboats.com.au

TITLE 8.5M-T1 HULL & POD
 ISOMETRIC VIEW

CLIENT

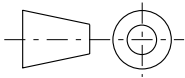
DO NOT SCALE DRAWING

 ALL DIMENSIONS IN
 MILLIMETRES

THIS DRAWING IS PROPERTY OF
 PETER BOOTH AND NOT TO BE
 COPIED IN WHOLE OR PART
 WITHOUT WRITTEN PERMISSION
 FROM PETER BOOTH

DRAWN BY P.H. BOOTH

DATE 18/04/09

SCALE
 1:25

DRG No
 D85-T1-01

REV.
 0

A3

REVISION

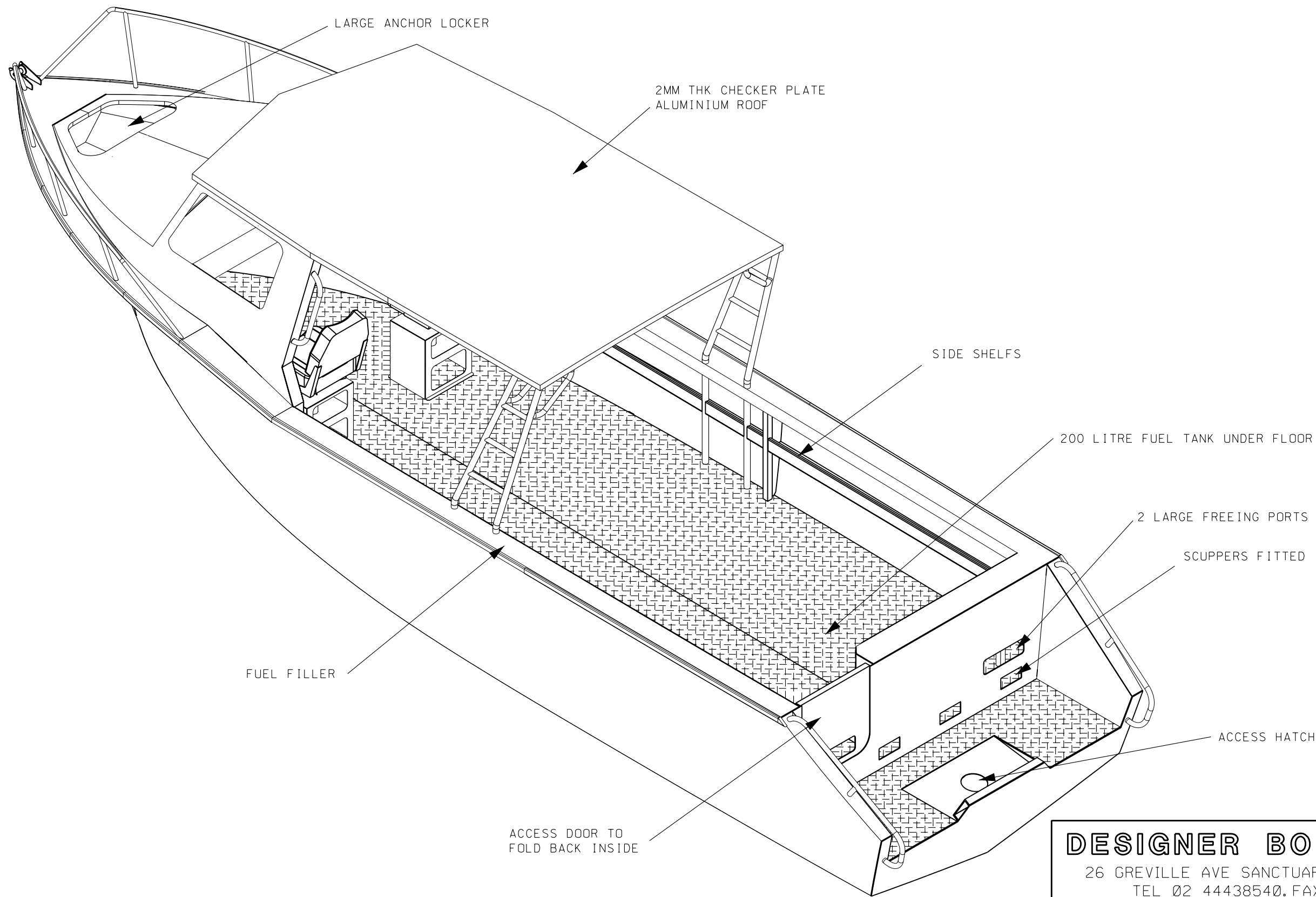

RIGHT ISOMETRIC VIEW

DESIGNER BOATS AUST

26 GREVILLE AVE SANCTUARY POINT 2540 N.S.W.
 TEL 02 44438540. FAX 02 44438470.
 WEB: www.designerboats.com.au

TITLE **8.5M-T1 HULL & POD**
RIGHT ISOMETRIC VIEW

CLIENT

DO NOT SCALE DRAWING

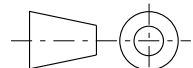

ALL DIMENSIONS IN MILLIMETRES

THIS DRAWING IS PROPERTY OF PETER BOOTH AND NOT TO BE COPIED IN WHOLE OR PART WITHOUT WRITTEN PERMISSION FROM PETER BOOTH

DRAWN BY P.H. BOOTH

DATE 18/04/09

SCALE 1:25

DRG No D85-T1-02

REV. 0

A3

REVISION

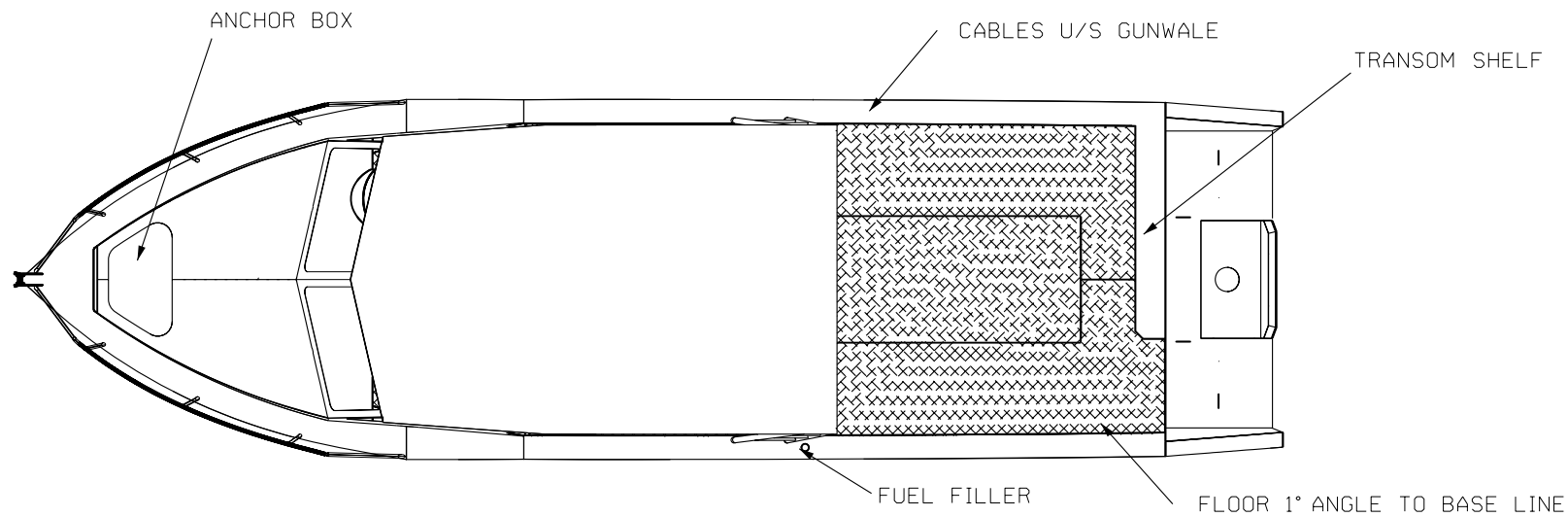

PLAN

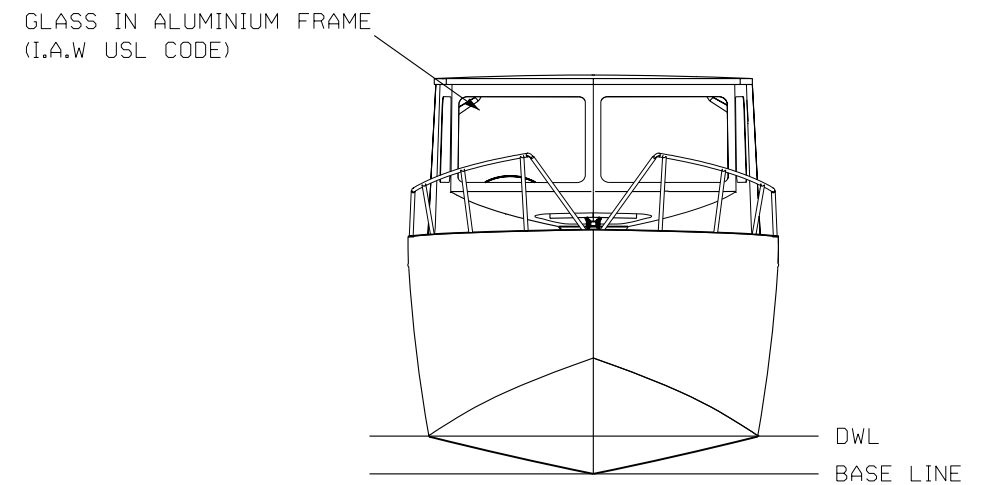

BODY

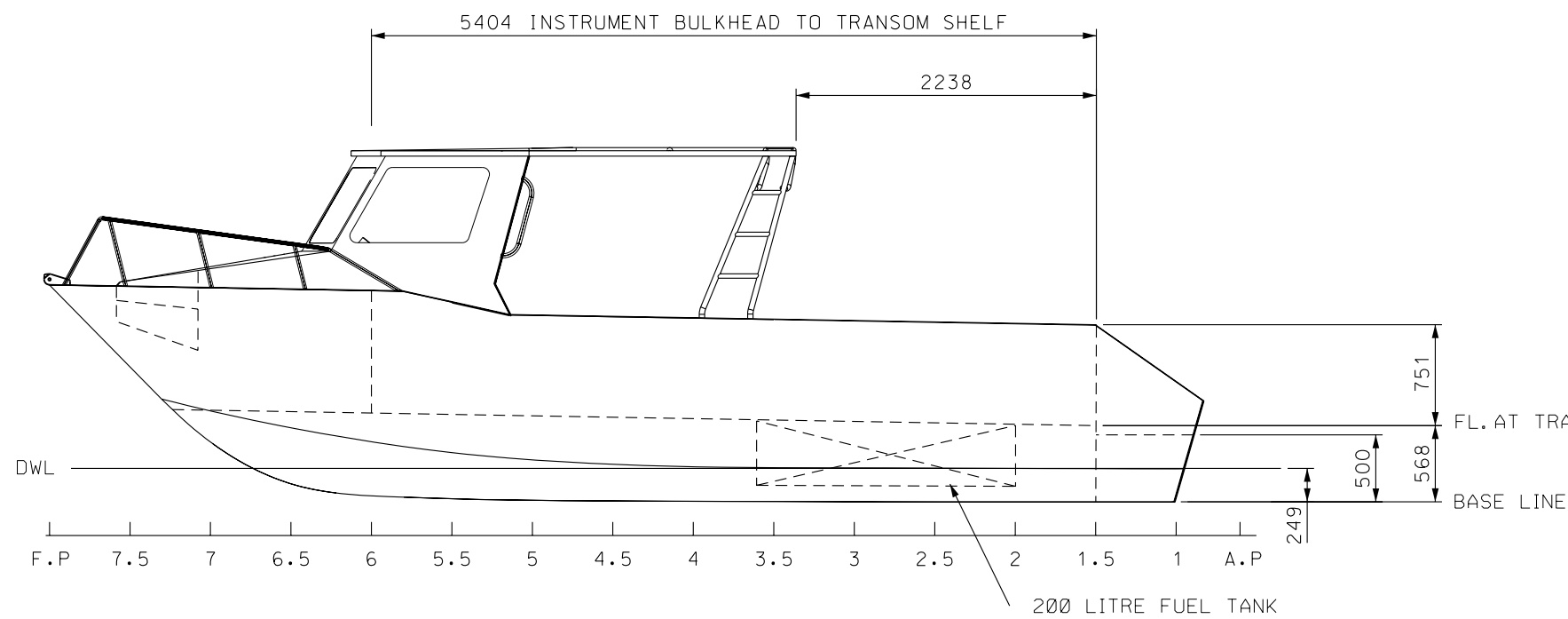

PROFILE

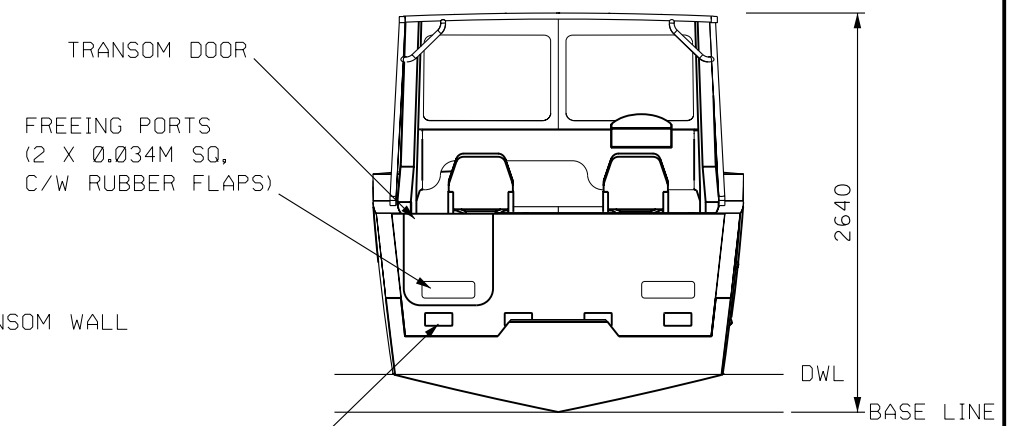

REAR BODY

PARTICULARS
 DISPLACEMENT: 1538 Kgs (S.W)
 LENGTH OVERALL 8.816 m
 LENGTH LOAD WATERLINE: 6.993 m
 BEAM AT DECK: 2.450 m
 BEAM AT DWL: 2.183 m
 MAX FREEBOARD 1.365 m
 DEAD RISE AT TRANSOM 14°
 DRAFT: 0.250 m
 MAX: 318 HP
 MASS CONTROLS, MOTOR & BATTERIES: 340KGS
 FUEL: 200 LITRES
 MAX CAPACITY: 10 DIVERS + 2 CREW
 TOTAL FREEING PORT AREA = 0.125M SQ

DESIGNER BOATS AUST

26 GREVILLE AVE SANCTUARY POINT 2540 N.S.W.
 TEL 02 44438540. FAX 02 44438470.
 WEB: www.designerboats.com.au

TITLE **8.5M-T1 HULL & POD
 GENERAL ARRANGEMENT**

CLIENT

DRAWN BY P.H. BOOTH

DATE 18/04/09

SCALE 1:50

DRG No D85-T1-03

REV. 0

A3

DO NOT SCALE DRAWING

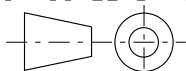

ALL DIMENSIONS IN MILLIMETRES

THIS DRAWING IS PROPERTY OF PETER BOOTH AND NOT TO BE COPIED IN WHOLE OR PART WITHOUT WRITTEN PERMISSION FROM PETER BOOTH

REVISION

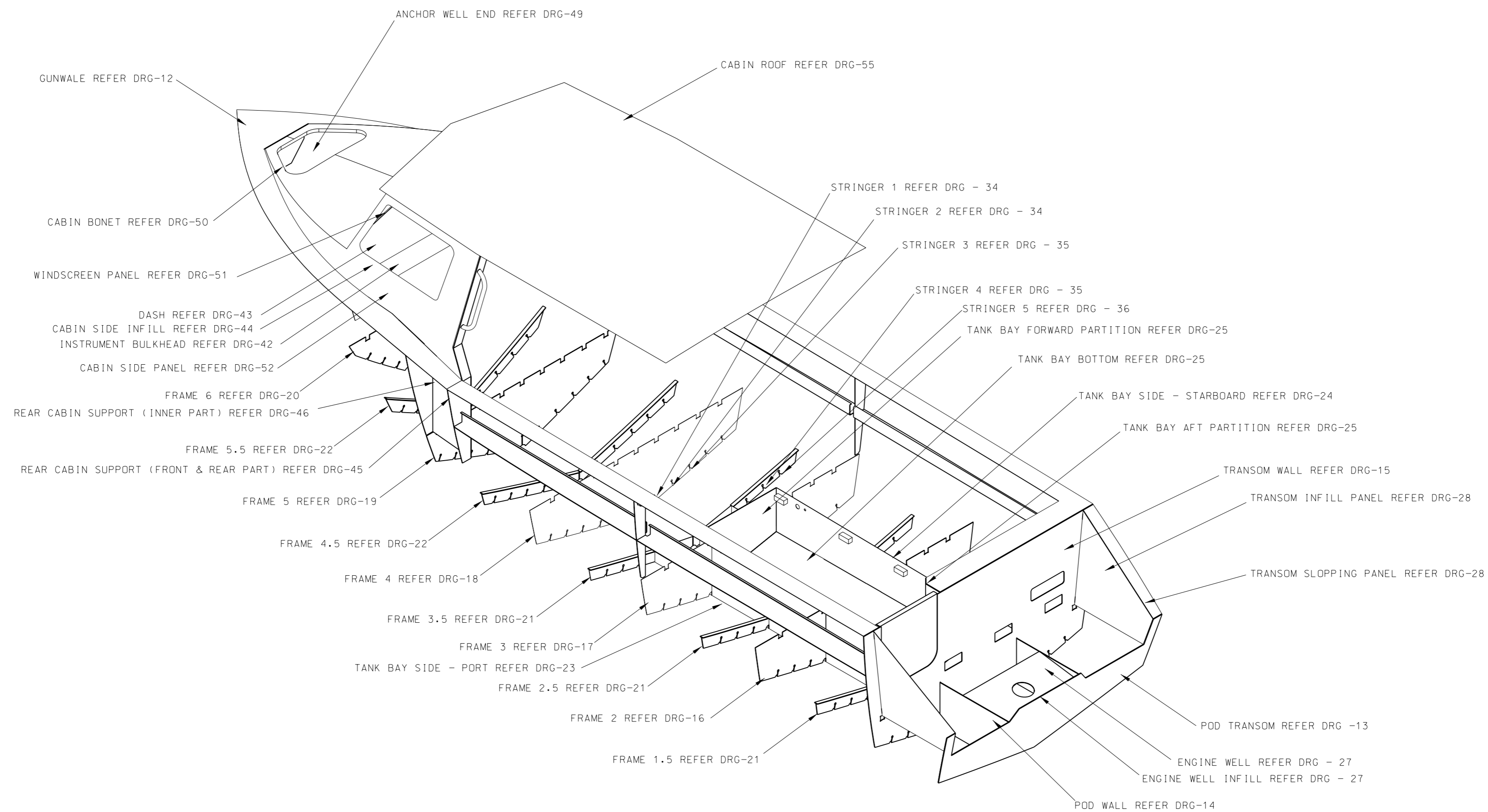

STRUCTURE ARRANGEMENT

DESIGNER BOATS AUST

26 GREVILLE AVE SANCTUARY POINT 2540 N.S.W.
 TEL 02 44438540. FAX 02 44438470.
 WEB: www.designerboats.com.au

TITLE **8.5M-T1 HULL & POD
 STRUCTURE ARRANGEMENT**

CLIENT

DRAWN BY P.H. BOOTH

DATE 18/04/09

DO NOT SCALE DRAWING

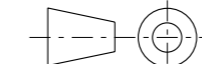

ALL DIMENSIONS IN
 MILLIMETRES

THIS DRAWING IS PROPERTY OF
 PETER BOOTH AND NOT TO BE
 COPIED IN WHOLE OR PART
 WITHOUT WRITTEN PERMISSION
 FROM PETER BOOTH

SCALE
 1:25

DRG No
D85-T1-04

REV.
 0

A2

REVISION

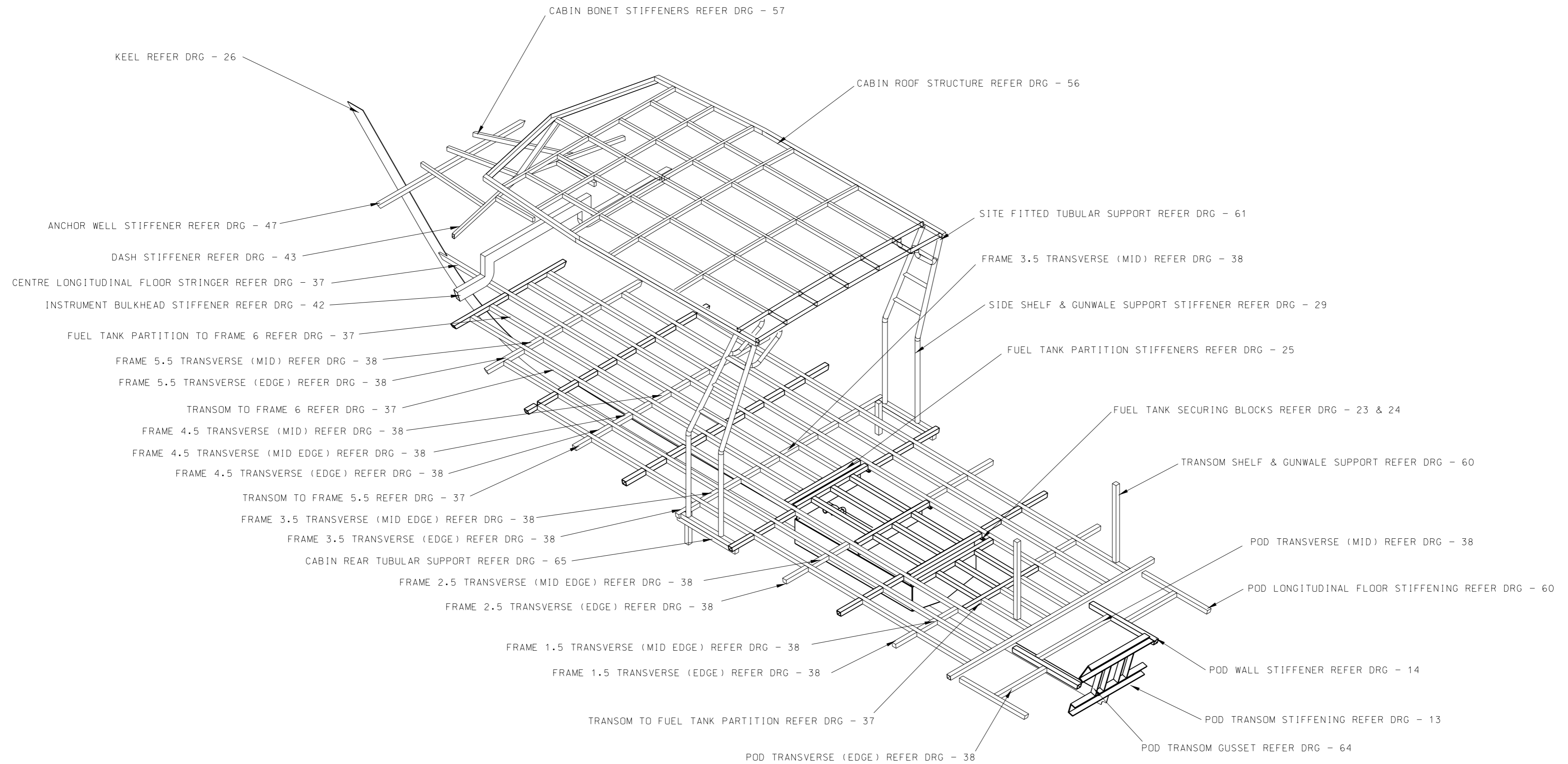

MAIN FRAME STIFFENING - REFER FRAME DRAWINGS

SHS & MAIN STRUCTURE ARRANGEMENT

DESIGNER BOATS AUST
 26 GREVILLE AVE SANCTUARY POINT 2540 N.S.W.
 TEL 02 44438540. FAX 02 44438470.
 WEB: www.designerboats.com.au

TITLE **8.5M-T1 HULL & POD
 SHS & MAIN STRUCTURE
 ARRANGEMENT**

CLIENT

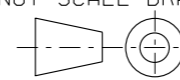
DO NOT SCALE DRAWING

 ALL DIMENSIONS IN
 MILLIMETRES

THIS DRAWING IS PROPERTY OF
 PETER BOOTH AND NOT TO BE
 COPIED IN WHOLE OR PART
 WITHOUT WRITTEN PERMISSION
 FROM PETER BOOTH

DRAWN BY P.H. BOOTH

DATE 18/04/09

SCALE 1:25

DRG No D85-T1-05

REV. 0

A2

REVISION

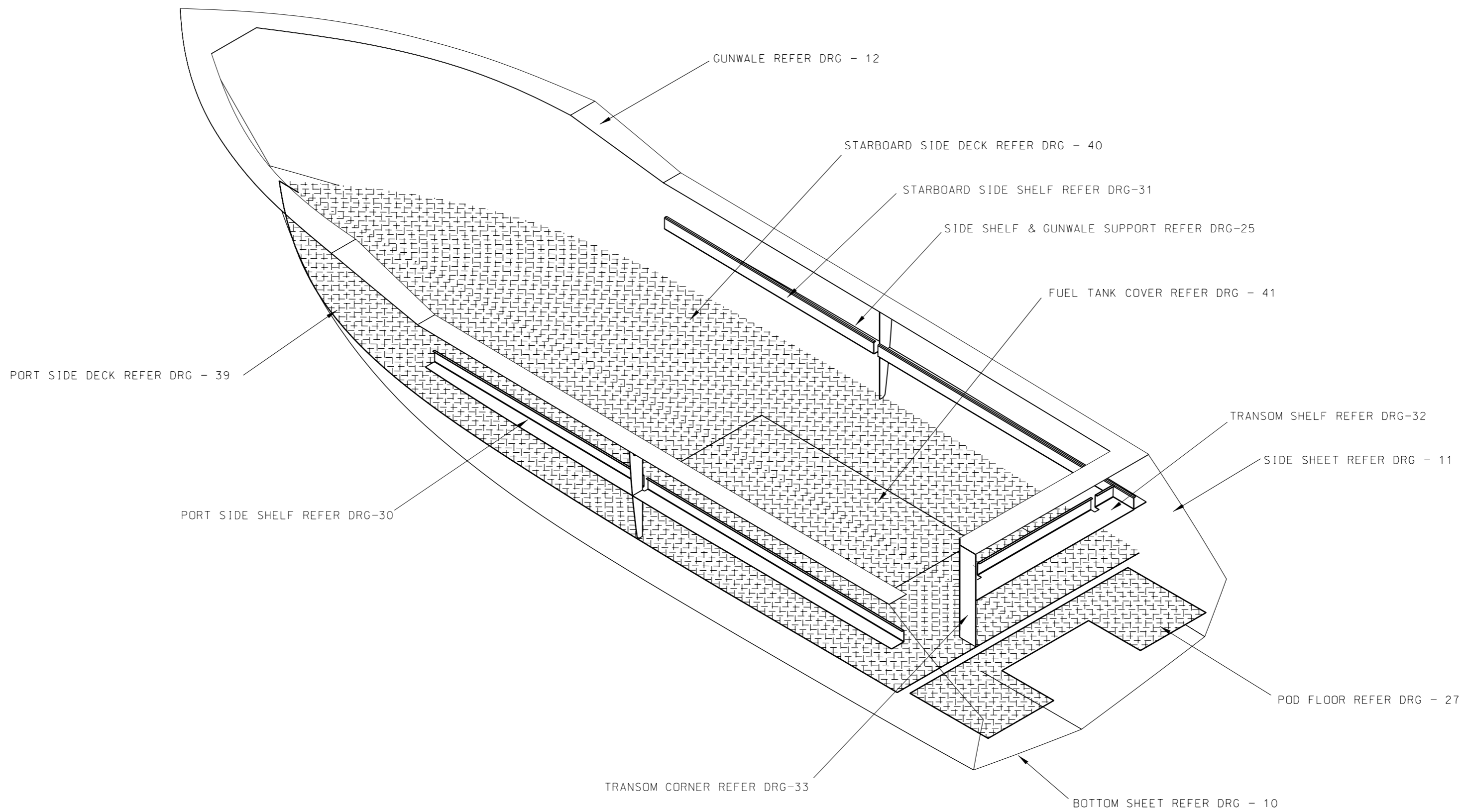

MAIN PLATE LAYOUT DRAWING

DESIGNER BOATS AUST
 26 GREVILLE AVE SANCTUARY POINT 2540 N.S.W.
 TEL 02 44438540. FAX 02 44438470.
 WEB: www.designerboats.com.au

TITLE **8.5M-T1 HULL & POD
 MAIN PLATE LAYOUT
 DRAWING**

CLIENT

DRAWN BY P.H. BOOTH DATE 18/04/09

SCALE 1:25 DRG No D85-T1-06 REV. 0 A2

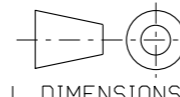
DO NOT SCALE DRAWING

 ALL DIMENSIONS IN MILLIMETRES

THIS DRAWING IS PROPERTY OF PETER BOOTH AND NOT TO BE COPIED IN WHOLE OR PART WITHOUT WRITTEN PERMISSION FROM PETER BOOTH

REVISION