

ISOMETRIC VIEW

PARTICULARS
 DISPLACEMENT: 1356 Kgs (S.W)
 LENGTH OVERALL: 6.57 m
 LENGTH LOAD WATERLINE: 5.276 m
 BEAM AT DECK: 2.40 m
 BEAM AT DWL: 2.139 m
 MAX FREEBOARD: 1.139 m
 DEAD RISE AT TRANSOM 14°
 DRAFT: 0.297 m
 LCF 4.340 m AFT OF F.P
 PRISMATIC COEFFICIENT (Cp): 0.696
 BLOCK COEFFICIENT (Cb): 0.395
 WATERPLANE COEFFICIENT (Cw): 0.776
 KG/CM 90
 VCG: TBA m ABOVE KEEL
 LCG: TBA m AFT OF F.P
 LCB: 4.463 m AFT OF F.P
 VCB: 0.095m BELOW DWL
 BOUYANCY FOAM DENSITY: 30KG/M CUBIC
 BOUYANCY FOAM REQUIRED: NOT REQUIRED

DESIGNER BOATS AUST

26 GREVILLE AVE SANCTUARY POINT 2540 N.S.W.
 TEL 02 44438540. FAX 02 44438470.
 WEB www.designerboats.com.au

TITLE **6.5M-T1 HULL & POD**
ISOMETRIC VEIW

CLIENT

DO NOT SCALE DRAWING

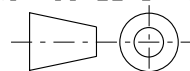

ALL DIMENSIONS IN
 MILLIMETRES

THIS DRAWING IS PROPERTY OF
 PETER BOOTH AND NOT TO BE
 COPIED IN WHOLE OR PART
 WITHOUT WRITTEN PERMISSION
 FROM PETER BOOTH

DRAWN BY P.H. BOOTH

DATE 29/10/07

SCALE
 1:20

DRG No
 D65-T1-01

REV.
 0

A3

REVISION

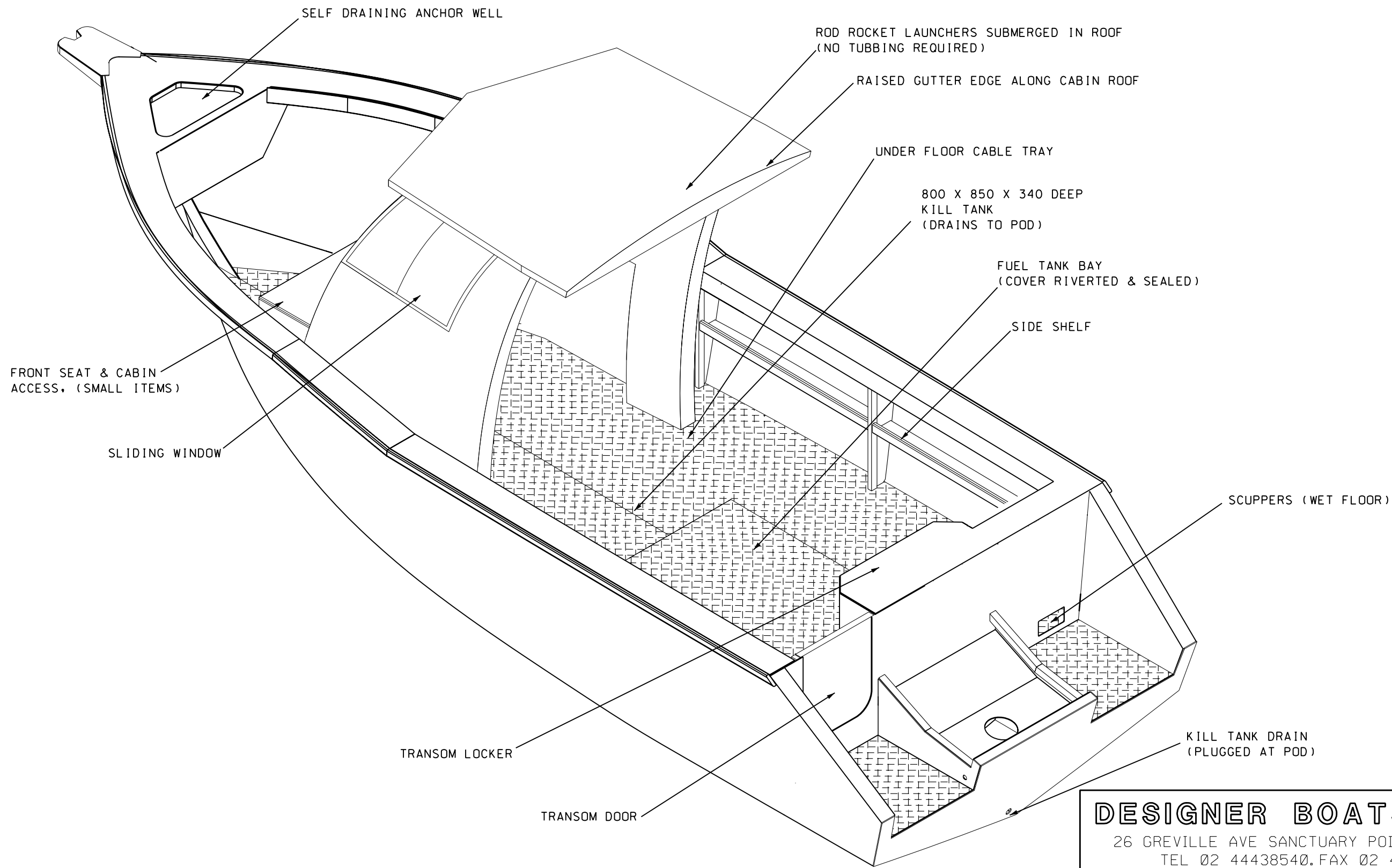

RIGHT ISOMETRIC VIEW

DESIGNER BOATS AUST

26 GREVILLE AVE SANCTUARY POINT 2540 N.S.W.
 TEL 02 44438540. FAX 02 44438470.
 WEB www.designerboats.com.au

TITLE **6.5M-T1 HULL & POD**
RIGHT ISOMETRIC VEIW

CLIENT

DO NOT SCALE DRAWING

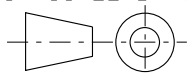

ALL DIMENSIONS IN
MILLIMETRES

THIS DRAWING IS PROPERTY OF
PETER BOOTH AND NOT TO BE
COPIED IN WHOLE OR PART
WITHOUT WRITTEN PERMISSION
FROM PETER BOOTH

DRAWN BY P.H. BOOTH

DATE 29/10/07

SCALE
1:20

DRG No
D65-T1-02

REV.
0

A3

REVISION

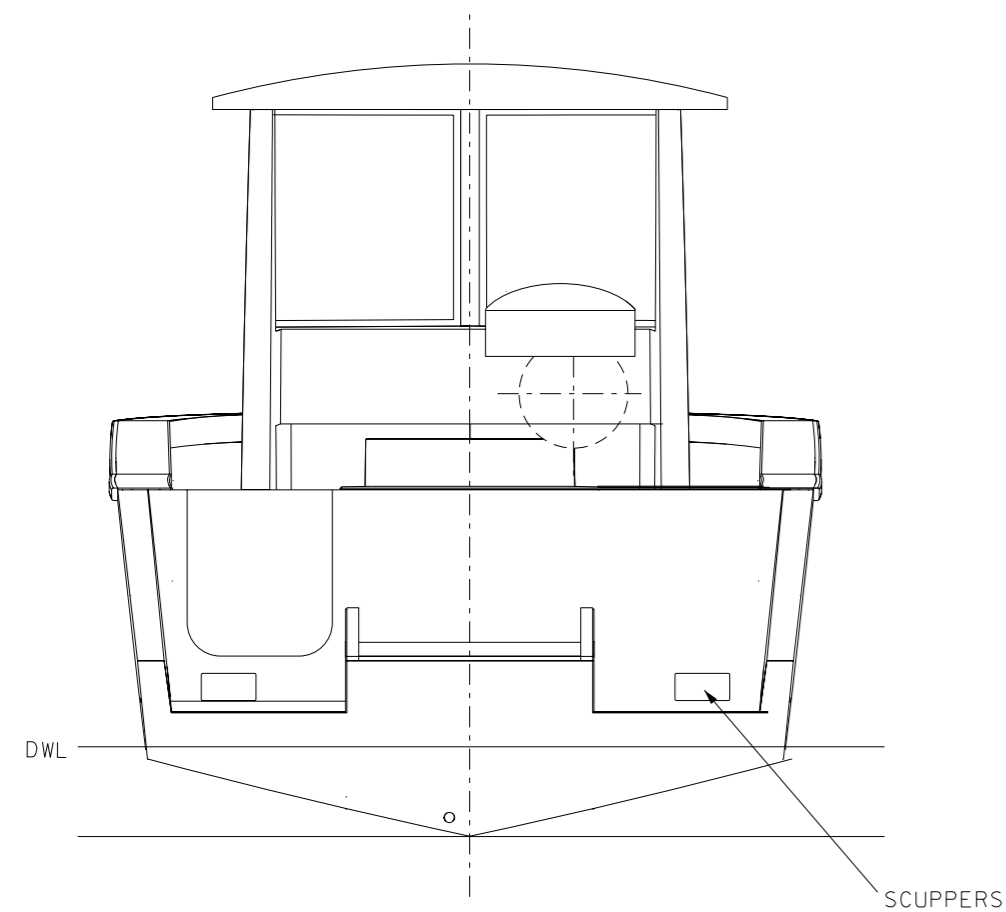

REAR BODY

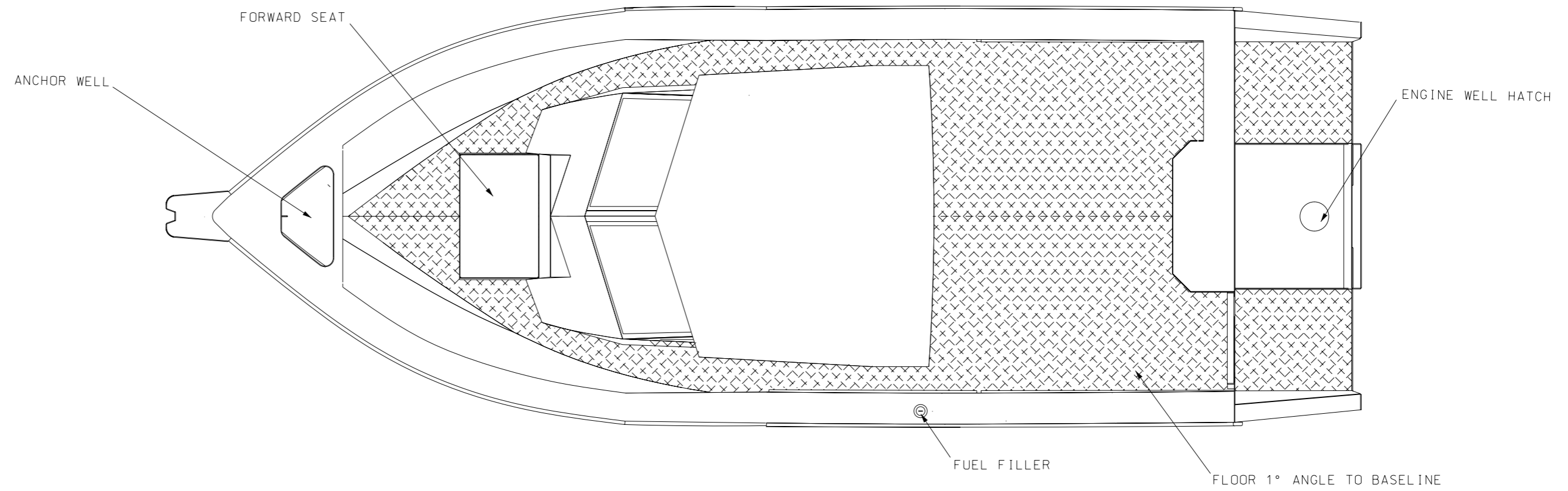

PLAN

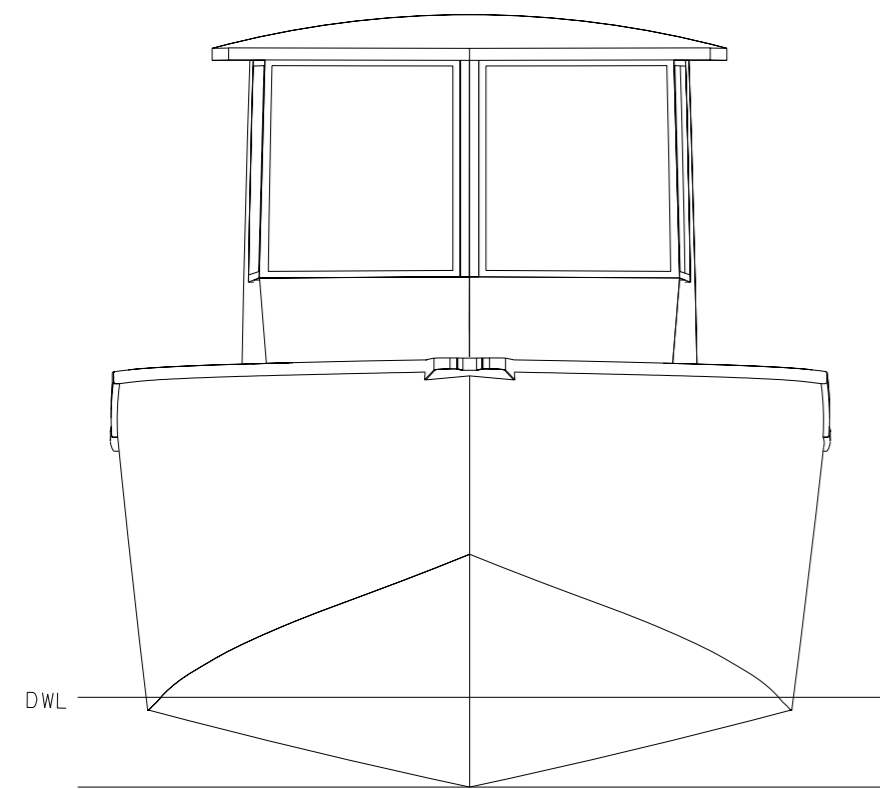

BODY

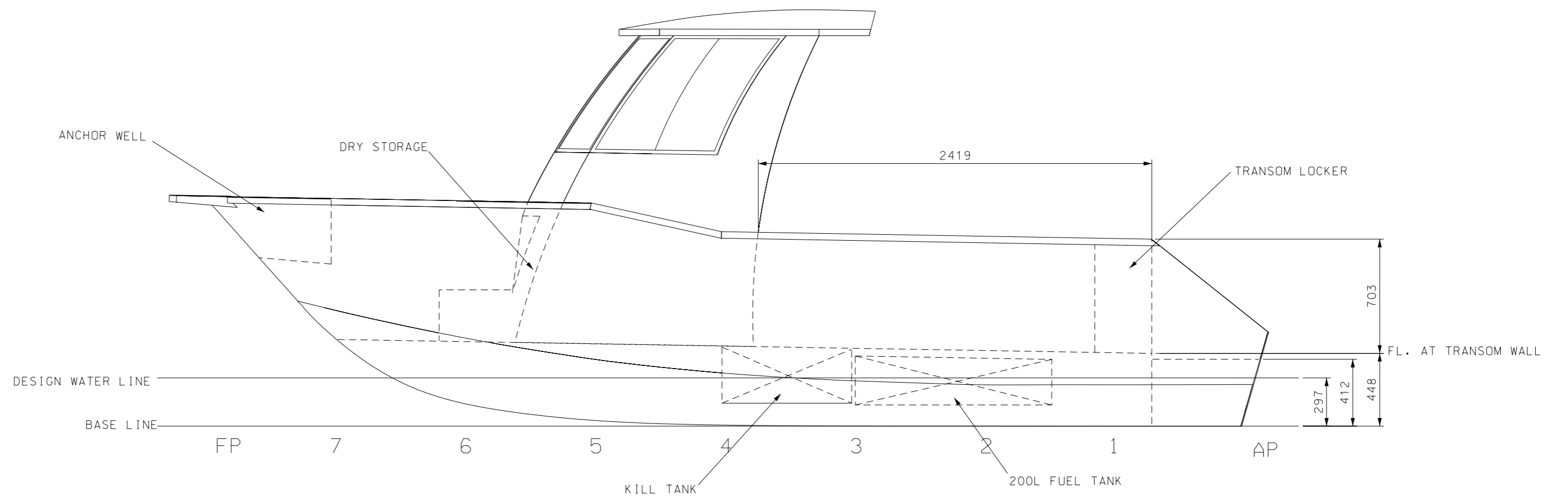

PROFILE

PARTICULARS
 DISPLACEMENT: 1356 Kgs (S.W)
 LENGTH OVERALL 6.570 m
 LENGTH LOAD WATERLINE: 5.276 m
 BEAM AT DECK: 2.40 m
 BEAM AT DWL: 2.139 m
 MAX FREEBOARD 1.139 m
 DEAD RISE AT TRANSOM 14°
 DRAFT: .297 m
 ENGINE: 150 HP (REC)
 ENGINE: 240 HP (MAX)
 FUEL: 200 LITRES

DESIGNER BOATS AUST
 26 GREVILLE AVE SANCTUARY POINT 2540 N.S.W.
 TEL 02 44438540. FAX 02 44438470.
 WEB. www.designerboats.com.au

TITLE 6.5M-T1 HULL & POD
 GENERAL ARRANGEMENT

CLIENT

DRAWN BY P. H. BOOTH DATE 29/10/07

SCALE 1:25 DRG No D65-T1-03 REV. 0 A2

DO NOT SCALE DRAWING

 ALL DIMENSIONS IN MILLIMETRES

THIS DRAWING IS PROPERTY OF PETER BOOTH AND NOT TO BE COPIED IN WHOLE OR PART WITHOUT WRITTEN PERMISSION FROM PETER BOOTH

REVISION