

PARTICULARS  
 DISPLACEMENT: 800 Kgs (S.W-NO CREW)  
 LENGTH OVERALL 5.467 m  
 LENGTH LOAD WATERLINE: 4.485 m  
 BEAM AT DECK: 2.2 m  
 BEAM AT DWL: 1.983 m  
 MAX FREEBOARD 0.662 m  
 DEAD RISE AT TRANSOM 11.5°  
 DRAFT: 0.207 m  
 LCF 3.477 m AFT OF F.P  
 PRISMATIC COEFFICIENT (Cp): 0.794  
 BLOCK COEFFICIENT (Cb): 0.424  
 WATERPLANE COEFFICIENT (Cw): 0.835  
 KG/CM 76.325  
 VCG: 0.293 m ABOVE DWL  
 LCG: 3.847 m AFT OF F.P  
 LCB: 3.547 m AFT OF F.P  
 VCB: 0.061 m BELOW DWL  
 BOUYANCY FOAM DENSITY: 30KG/M CUBIC  
 BOUYANCY FOAM REQUIRED: 0.70 CUBIC M

**DESIGNER BOATS AUST**

26 GREVILLE AVE SANCTUARY POINT 2540 N.S.W.  
 TEL 02 44438540. FAX 02 44438470.  
 WEB www.designerboats.com.au

TITLE D5.4M-P1-V-NOSE PUNT  
 ISOMETRIC VIEW

CLIENT

ISOMETRIC VIEW

DO NOT SCALE DRAWING

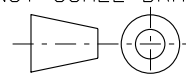

ALL DIMENSIONS IN  
 MILLIMETRES

THIS DRAWING & DESIGN  
 IS PROPERTY OF  
 PETER BOOTH AND NOT TO BE  
 COPIED IN WHOLE OR PART  
 WITHOUT WRITTEN PERMISSION  
 FROM PETER BOOTH

DRAWN BY P.H. BOOTH

DATE 14/06/08

SCALE  
 1:20

DRG No  
 D54-P1-01

REV.  
 0

A3

REVISION

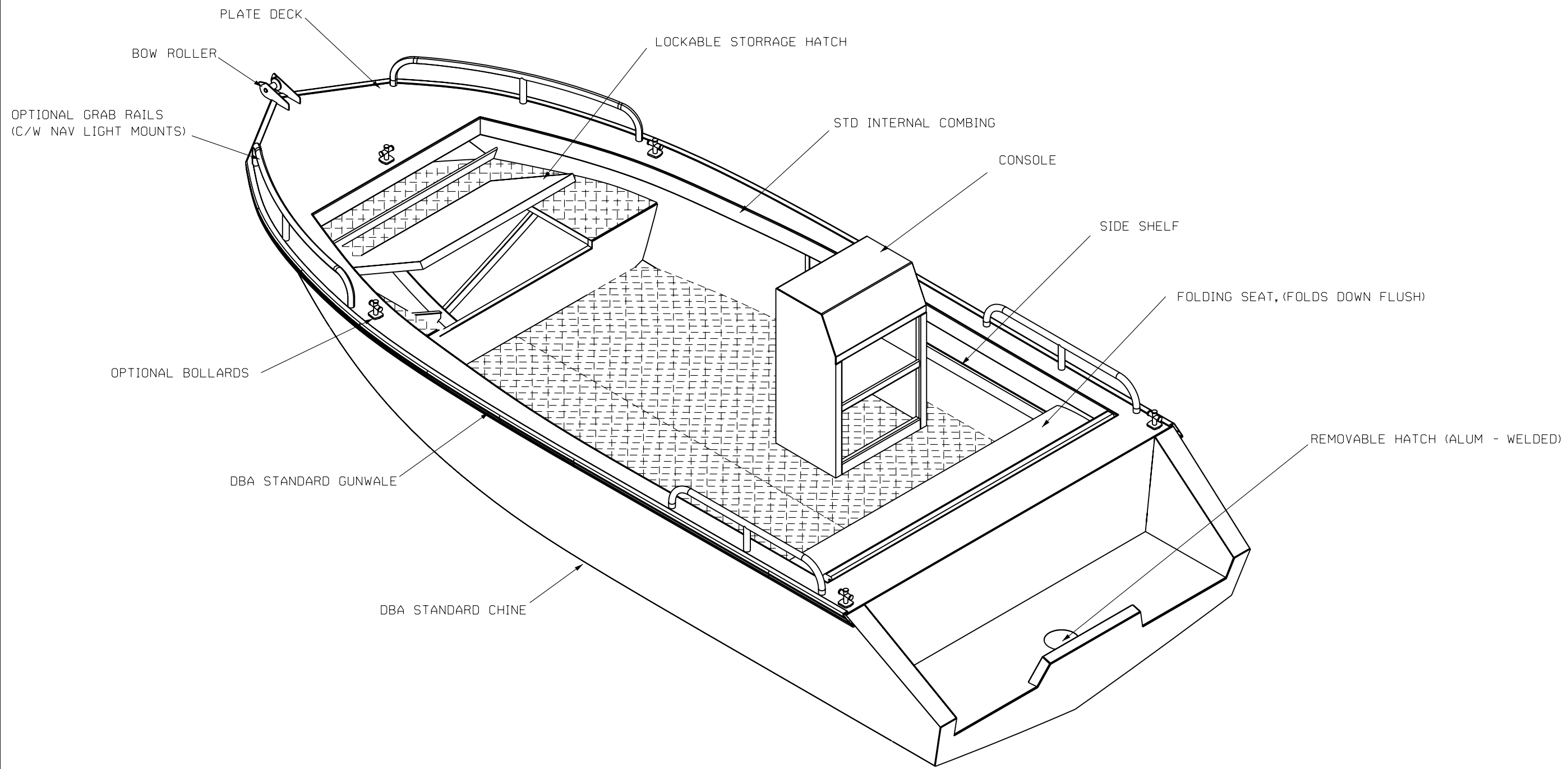

RIGHT ISOMETRIC VIEW

**DESIGNER BOATS AUST**  
 26 GREVILLE AVE SANCTUARY POINT 2540 N.S.W.  
 TEL 02 44438540. FAX 02 44438470.  
 WEB www.designerboats.com.au

TITLE **D5.4M-P1-V-NOSE PUNT**  
**RIGHT ISOMETRIC VIEW**

CLIENT

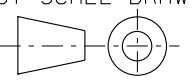
DO NOT SCALE DRAWING  
  
 ALL DIMENSIONS IN  
 MILLIMETRES

THIS DRAWING & DESIGN  
 IS PROPERTY OF  
 PETER BOOTH AND NOT TO BE  
 COPIED IN WHOLE OR PART  
 WITHOUT WRITTEN PERMISSION  
 FROM PETER BOOTH

DRAWN BY P.H. BOOTH		DATE 14/06/08	
SCALE 1:20	DRG No D54-P1-02	REV. 0	A3

REVISION

FUEL FILLER

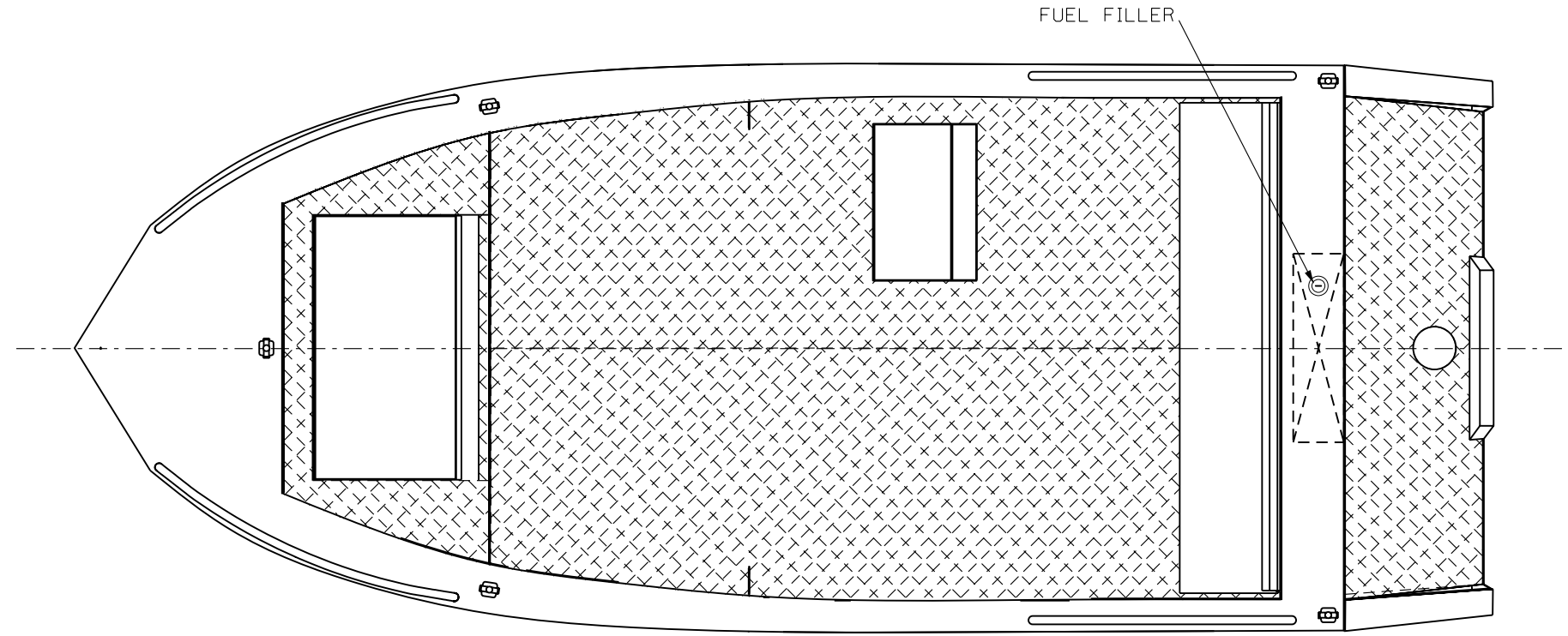

NOTE  
 CONSOLE CAN BE MOVED TRANSVERSE  
 TO OWN REQUIREMENTS  
 HOWEVER  
 CABLE TRAY WILL NEED TO BE CUT IN  
 TO SUIT NEW LOCATION, CONTACT DBA  
 FOR MORE DETAILS  
 CABLE TRAY NOT IN BILL OF MATERIALS  
 OR CUTTING FILES

PLAN

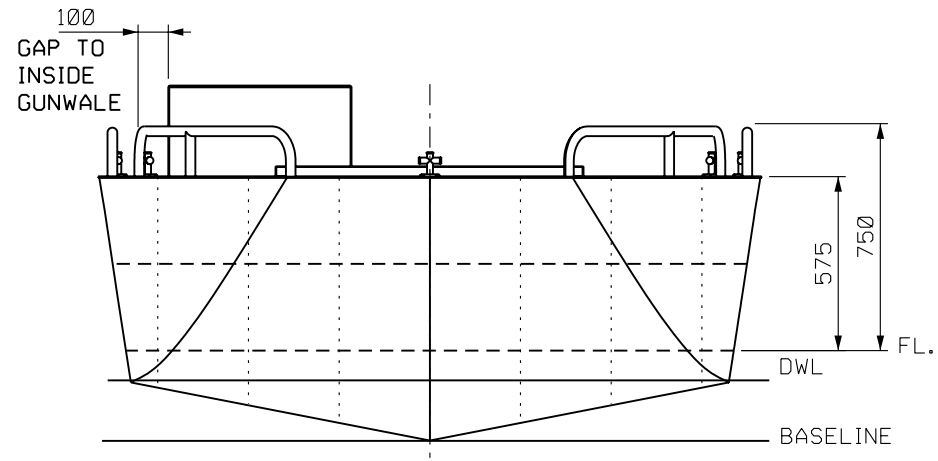

BODY

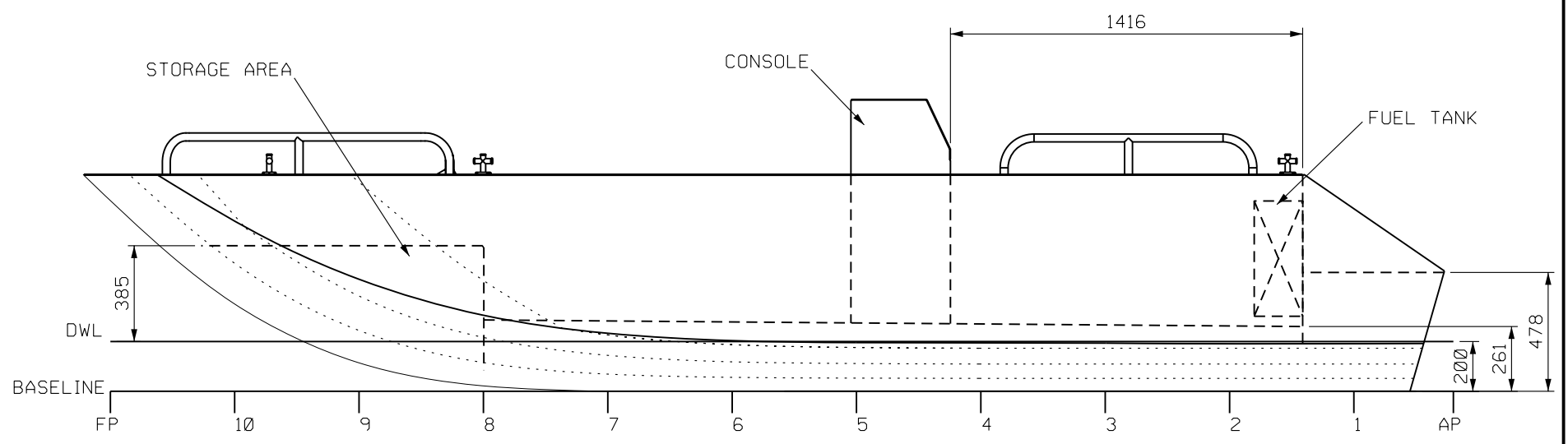

PROFILE

**PARTICULARS**  
 DISPLACEMENT: 800 Kgs (S.W)  
 LENGTH OVERALL 5.467 m  
 LENGTH LOAD WATERLINE: 4.485 m  
 BEAM AT DECK: 2.2 m  
 BEAM AT DWL: 1.983 m  
 MAX FREEBOARD 0.662 m  
 DEAD RISE AT TRANSOM 11.5°  
 DRAFT: .207 m  
 ENGINE: 150 HP (ABP MAX)  
 ENGINE: 90 HP (REC)  
 FUEL: 60 LITRES

**DESIGNER BOATS AUST**  
 26 GREVILLE AVE SANCTUARY POINT 2540 N.S.W.  
 TEL 02 44438540. FAX 02 44438470.  
 WEB www.designerboats.com.au

TITLE **D5.4M-P1-V-NOSE PUNT  
 GENERAL ARRANGEMENT**

CLIENT

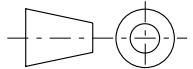
DO NOT SCALE DRAWING  
  
 ALL DIMENSIONS IN  
 MILLIMETRES

THIS DRAWING & DESIGN  
 IS PROPERTY OF  
 PETER BOOTH AND NOT TO BE  
 COPIED IN WHOLE OR PART  
 WITHOUT WRITTEN PERMISSION  
 FROM PETER BOOTH

DRAWN BY P. H. BOOTH

DATE 14/06/08

SCALE 1:25

DRG No D54-P1-03

REV. 0

A3

REVISION

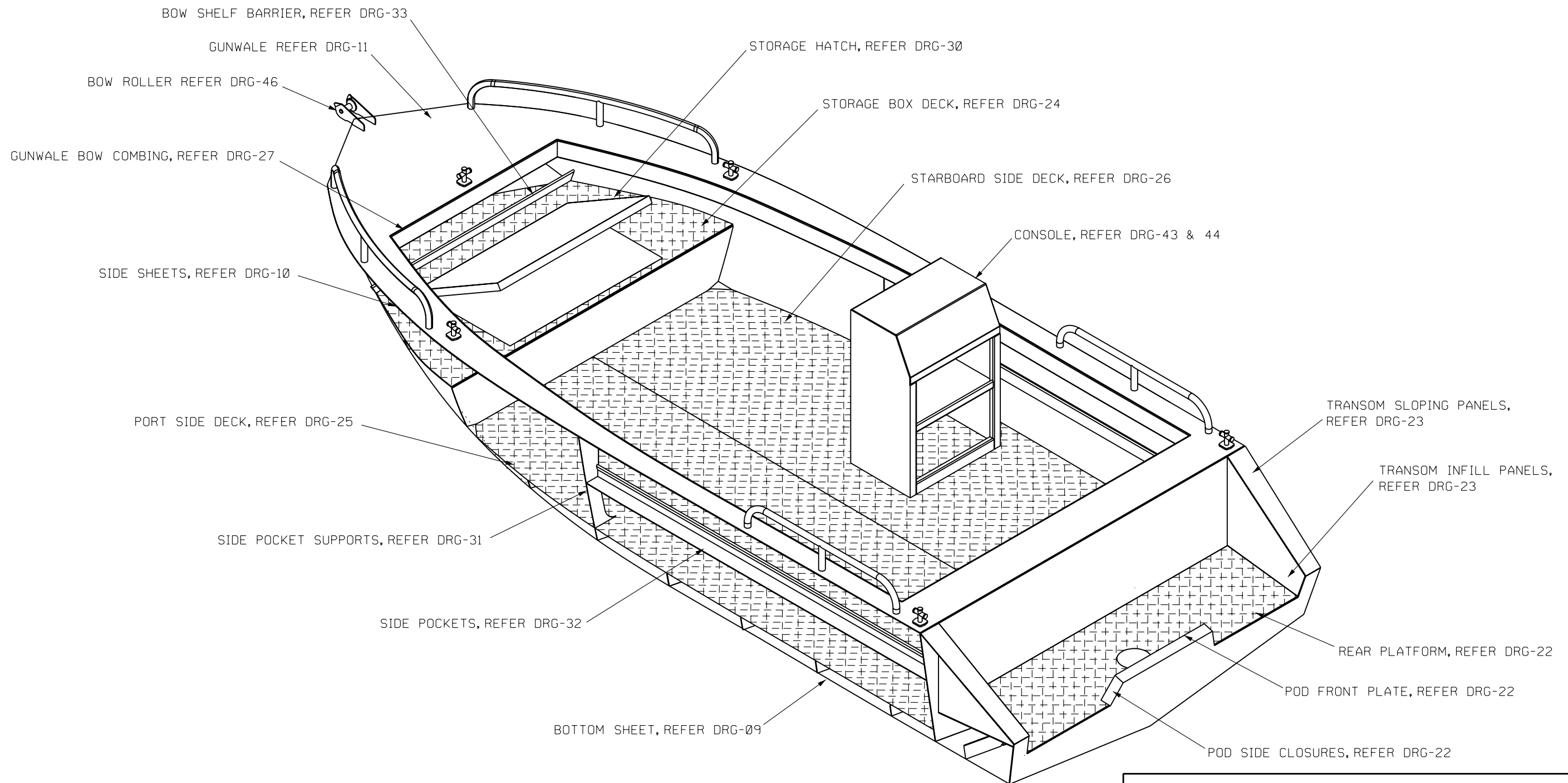

**DESIGNER BOATS AUST**  
 26 GREVILLE AVE SANCTUARY POINT 2540 N.S.W.  
 TEL 02 44438540. FAX 02 44438470.  
 WEB www.designerboats.com.au

TITLE **D5.4M-P1-V-NOSE PUNT  
 PLATE CALL UP DIAGRAM**

CLIENT

DO NOT SCALE DRAWING		THIS DRAWING & DESIGN IS PROPERTY OF PETER BOOTH AND NOT TO BE COPIED IN WHOLE OR PART WITHOUT WRITTEN PERMISSION FROM PETER BOOTH		DRAWN BY P.H. BOOTH		DATE 14/06/08	
ALL DIMENSIONS IN MILLIMETRES		SCALE 1:20	DRG No D54-P1-04	REV. 0	A3	REVISION	

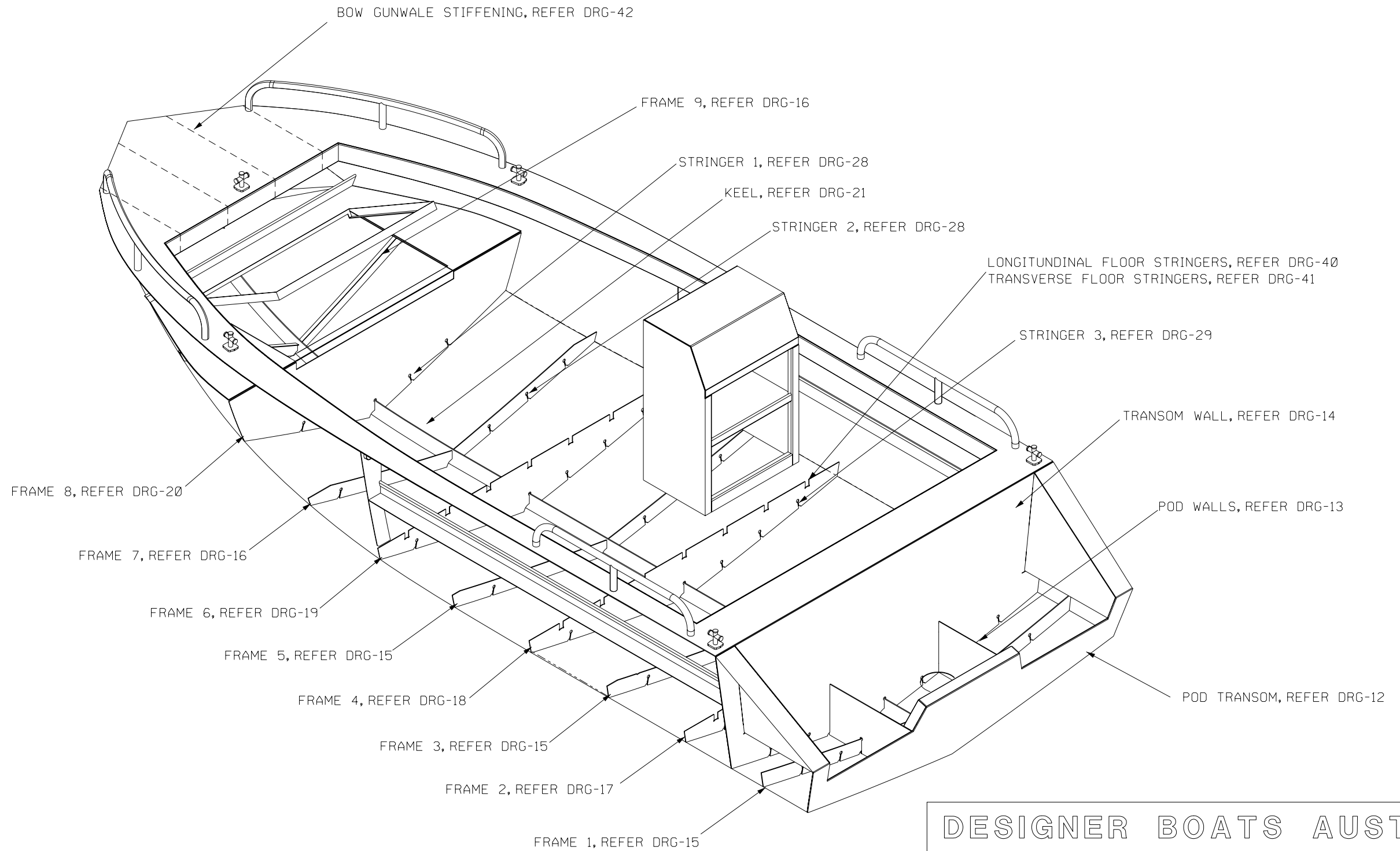

DESIGNER BOATS AUST  
 26 GREVILLE AVE SANCTUARY POINT 2540 N.S.W.  
 TEL 02 44438540. FAX 02 44438470.  
 WEB www.designerboats.com.au

TITLE D5.4M-P1-V-NOSE PUNT  
 STRUCTURAL MEMBER  
 CALLUP DIAGRAM

CLIENT

DRAWN BY P.H. BOOTH

DATE 14/06/08

SCALE  
 1:20

DRG No  
 D54-P1-05

REV.  
 0

A3

DO NOT SCALE DRAWING

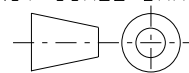

ALL DIMENSIONS IN  
 MILLIMETRES

THIS DRAWING & DESIGN  
 IS PROPERTY OF  
 PETER BOOTH AND NOT TO BE  
 COPIED IN WHOLE OR PART  
 WITHOUT WRITTEN PERMISSION  
 FROM PETER BOOTH

REVISION

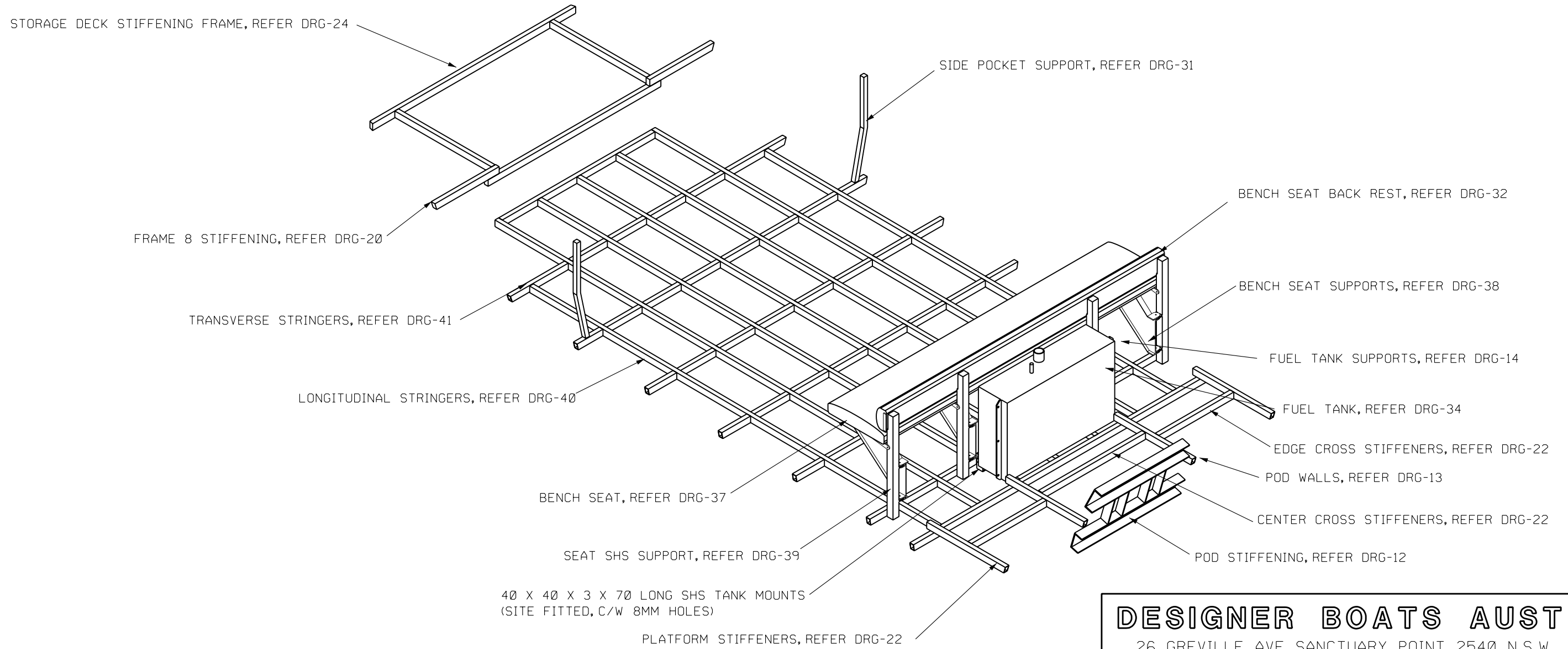

**DESIGNER BOATS AUST**  
 26 GREVILLE AVE SANCTUARY POINT 2540 N.S.W.  
 TEL 02 44438540. FAX 02 44438470.  
 WEB www.designerboats.com.au

TITLE D5.4M-P1-V-NOSE PUNT  
 RHS, SEAT & TANK  
 CALLUP DIAGRAM

CLIENT

DO NOT SCALE DRAWING		THIS DRAWING & DESIGN IS PROPERTY OF PETER BOOTH AND NOT TO BE COPIED IN WHOLE OR PART WITHOUT WRITTEN PERMISSION FROM PETER BOOTH		DRAWN BY P.H. BOOTH	DATE 14/06/08
ALL DIMENSIONS IN MILLIMETRES		SCALE 1:20	DRG No D54-P1-06	REV. 0	A3

REVISION